

Got questions on how the GT707 series HMI can maximize  
your process and improve quality?

Contact Ramco Innovations today!

Email us at [nsales@ramcoi.com](mailto:nsales@ramcoi.com)

PROGRAMMABLE DISPLAY

GT707 series

# User's Manual

Hardware

# Safety Precautions

Observe the following notices to ensure personal safety or to prevent accidents.  
To ensure that you use this product correctly, read this User's Manual thoroughly before use.  
Make sure that you fully understand the product and information on safety.  
This manual uses two safety flags to indicate different levels of danger.

## **WARNING**

**If critical situations that could lead to user's death or serious injury is assumed by mishandling of the product:**

- Always take precautions to ensure the overall safety of your system, so that the whole system remains safe in the event of failure of this product or other external factor.
- DO NOT USE THE PROGRAMMABLE DISPLAY TO CONTROL SAFETY FEATURES OR OTHER CRITICAL OPERATIONS OF EQUIPMENT OR SYSTEMS. A COMMUNICATION ERROR (FOR ANY REASON) MIGHT PREVENT SUCH SAFETY FEATURES OR CRITICAL OPERATIONS FROM FUNCTIONING PROPERLY.
- Do not use this product in areas with inflammable gas. It could lead to an explosion.
- Exposing this product to excessive heat or open flames could cause damage to the lithium battery or other electronic parts.
- Battery may explode if mistreated. Do not recharge, disassemble or dispose of fire.

## **CAUTION**

**If critical situations that could lead to user's injury or only property damage is assumed by mishandling of the product.**

- To prevent excessive exothermic heat or smoke generation, use this product at the values less than the maximum of the characteristics and performance that are assured in these specifications.
- Do not dismantle or remodel the product. It could cause excessive exothermic heat or smoke generation.
- Do not touch the terminal while turning on electricity. It could lead to an electric shock.
- Use the external devices to function the emergency stop and interlock circuit.
- Connect the wires or connectors securely.  
The loose connection could cause excessive exothermic heat or smoke generation.
- Do not allow foreign matters such as liquid, flammable materials, metals to go into the inside of the product. It could cause excessive exothermic heat or smoke generation.
- Do not undertake construction (such as connection and disconnection) while the power supply is on. It could lead to an electric shock.
- The control force of the touch switches should be less than the specification of the product. Failure to do so could lead to a damage to the product or a personal injury.
- These touch switches operate using analog resistance membrane. Do not press more than one point on the screen at a time. Doing so might operate a switch located in the middle of the points pressed if one exists, and could lead to a damage to the facility or an accident.

# Copyright / Trademarks

- This manual and its contents are copyrighted.
- You may not copy this manual in whole or part, without written consent of Panasonic Industrial Devices SUNX Co., Ltd.
- Windows is a registered trademark of Microsoft Corporation in the United States and other countries.
- Ethernet is a registered trademark of Fuji Xerox Co., Ltd. and Xerox Corp.
- SDHC and SD logos are trademarks of SD-3C, LLC.
- All other company names and product names are trademarks or registered trademarks of their respective owners.

POT\_GT

## Introduction

---

Thank you for buying a Panasonic product. Before you use the product, please carefully read the installation instructions and the users manual, and understand their contents in detail to use the product properly.

## Types of Manual

---

- There are different types of users manual for the GT707 series, as listed below. Please refer to a relevant manual for the unit and purpose of your use.
- The manuals can be downloaded on our website:  
[http://industrial.panasonic.com/ac/e/dl\\_center/manual/](http://industrial.panasonic.com/ac/e/dl_center/manual/)

Unit name or purpose of use	Manual name	Manual code
Programmable Display GT707	GT707 User's Manual (Hardware)	WUME-GT707H
Screen Creation Tool GTWIN Ver.3	Terminal GTWIN Ver.3 Reference Manual	ACGM0357V9EN
General-purpose serial communication	GT series General-purpose Serial Communication Manual (English Edition) (shared with conventional GT-series models)	ARCT1F356E

(Note 1): The GT-series General-purpose Serial Communication Manual have been created for GTWIN Ver. 2. The GTWIN Ver. 3 user interface is different.

# Table of Contents

<b>1. System Configuration.....</b>	<b>1-1</b>
1.1 List of Models .....	1-2
1.1.1 GT Series Main Unit .....	1-2
1.1.2 Options .....	1-2
1.2 Screen Creating Tool.....	1-3
1.2.1 Tools Required for Screen Creation.....	1-3
1.2.2 Software Usage Environment and Applicable Cables .....	1-3
<b>2. Names and Functions of Parts .....</b>	<b>2-1</b>
2.1 Names and Functions of Parts.....	2-2
2.1.1 GT707.....	2-2
2.1.2 Operation Mode Setting Switches .....	2-3
<b>3. Installation and Wiring .....</b>	<b>3-1</b>
3.1 Installation .....	3-2
3.1.1 Installation Environment.....	3-2
3.1.2 Restriction According to Mounting Directions .....	3-3
3.1.3 Installation Space .....	3-3
3.1.4 Mounting Screws .....	3-3
3.1.5 GT707 Installation Method .....	3-4
3.1.6 Installing in Vertical Orientation.....	3-5
3.2 Wiring the Power Supply .....	3-6
3.2.1 Precautions on Wiring .....	3-6
3.2.2 Wiring the Power Supply .....	3-6
3.2.3 Wiring of Terminal Block .....	3-7

3.2.4	Grounding.....	3-8
3.3	Wiring of COM Port.....	3-9
3.3.1	Specifications of COM Port .....	3-9
3.3.2	Wiring Example of COM Port.....	3-10
3.4	Communication with PLC.....	3-12
3.4.1	Automatic Communication Settings Function .....	3-12
3.4.2	Through Function .....	3-13
3.5	Battery for Clock .....	3-14
3.5.1	Battery for Clock.....	3-14
3.5.2	How to Mount Battery for Clock .....	3-14
3.5.3	Lifetime and Time for Replacement of Battery for Clock .....	3-15
<b>4.</b>	<b>Troubleshooting .....</b>	<b>4-1</b>
4.1	What to Do If an Error Occurs.....	4-2
4.2	Error Codes and How to Handle Them .....	4-7
4.2.1	About Error Codes.....	4-7
4.2.2	GT707 Series Error Codes.....	4-7
4.2.3	When Connected to a FP Series PLC.....	4-9
4.2.4	When Performing General-purpose Serial Communication.....	4-10
<b>5.</b>	<b>Specifications.....</b>	<b>5-1</b>
5.1	GT707 Specifications .....	5-2
5.1.1	General Specifications .....	5-2
5.1.2	Performance Specifications .....	5-3
5.1.3	Function Specifications .....	5-4
5.1.4	Interface Specifications .....	5-5
5.2	Dimensions .....	5-6
5.2.1	GT707 Main Unit .....	5-6
5.2.2	For Connecting PLC (AFC8503/AFC8503S).....	5-7

# Before You Start

---

## ■ Usage conditions

- Ambient temperatures: 0 to +50 °C
- Ambient humidity should be 20 to 85% RH (at 25 °C) and non-condensing.
- Usable altitude: 2000 m above sea level or lower
- For use in pollution degree 2 environment
- Do not use it in the following environments.
  - Direct sunlight, wind and rain. (This product is not designed for outdoor use.)
  - Inflammable or corrosive gas.
  - Excessive airborne dust, metal particles or saline matter.
  - Benzene, paint thinner, alcohol or other organic solvents or strong alkaline solutions such as ammonia or caustic soda.
  - Direct vibration, shock or places always exposed to drop of water.
  - (This unit is warranted by IP65 for panel mounting, however, this applies to initial values.)
  - Influence from power transmission lines, high voltage equipment, power cables, power equipment, radio transmitters, or any other equipment that would generate high switching surges. (100 mm or more)

## ■ Static electricity

- Do not touch connector pins directly to prevent static electricity from causing damage.
- Always rid yourself of any static electricity before handling this product.
- If excessive static electricity is applied to the panel surface, the LCD panel may be damaged.

## ■ Power Supply

- Twist the wires of the power supply.
- The unit has sufficient noise immunity against the noise generated on the power line. However, it is recommended to take measures for reducing noise such as using an isolating transformer before supplying the power. And it is recommended to take measures such as installing a ferrite core.
- Allocate an independent wiring for each power supplying line, PLC etc and operating device.
- If using a power supply without a protective circuit, power should be supplied through a protective element such as fuse. Directly applying an abnormal voltage to the unit may cause the damage to the internal circuit.

## ■ Selection of wires

- Use a wire of which temperature rating is 75 °C or more.

### ■ Touch switches

- Always operate the touch switches with fingers. As the touch switches may be damaged due to the excessive load or shock (caused when being operated with any tools), the touch switches should be operated within the specified control force. Also, if the touch switches are pressed like kneading, the electrode may be worn out exceptionally, and cause the malfunction. Operate with a single touch of a switch.
- When touching the ends of top, bottom, right and left of a touch switch, a position more inside than the touched position may react. Therefore, do not place a switch smaller than 20 dots at the ends of the screen.
- The touch position may shift due to aging variation. If the touch position has shifted, please adjust it.

### ■ LCD panel

- Do not drop or have a strong impact on the programmable display unit as glass is used for the LCD panel.
- The liquid in the LCD panel is a hazardous substance. If the LCD panel is broken, do not put the leaked crystalline liquid into your mouse. Should it get into your mouse, immediately gargle, and consult a doctor. If it adheres to your skin or clothes, wash it away with soap.
- On the LCD panel, bright spots ( points always lit) or black spots (points always unlit) may appear, or the uneven brightness, flickers or crosstalk (appearance of unintended shades in the area no graphic or part is arranged) may occur depending on the operating conditions. Note that these phenomena are resulted from the basic characteristics of LCD panel not defects or failures of the product.

### ■ Battery

- Do not leave the battery in the unit when it is not used. There is a possibility of leak if it is left being discharged.

### ■ Scratch protection sheet

- A sheet is affixed to the touch panel to protect it from scratches when shipping. Please remove it before using the GT.

### ■ Cautions on handling a SD memory card

- The data saved in the SD memory card may be lost in the following cases. We assume no responsibility whatsoever for the lost of saved data.
  - 1) When a user or third party used the SD memory card incorrectly.
  - 2) When the SD memory card was affected by any static electricity or electrical noise.
  - 3) When the SD memory card was removed or the power supply of the GT unit was turned off while data was being read, written or deleted to/from the SD memory card.
- It is recommended to save important data in another media for backup.





# 1

## System Configuration

## 1.1 List of Models

### 1.1.1 GT Series Main Unit

Model	Display	Interface specifications	Power supply	Front panel color	Model No.
GT707	65536-color TFT color LCD (800x480 dots) LED backlight	COM port for connecting an external device RS-232C (D-sub 9-pin) Port for connecting tool software USB port (USB2.0 compliant)	24V DC	Black	AIG707WCL1G2

### 1.1.2 Options

#### ■ PLC connecting cables

Item name	Specifications	Model No.
PLC connecting cable	For connecting our FP-series TOOL port Cable length: 3 m GT707 side: D-sub 9-pin female connector PLC side: Mini-DIN 5-pin round male connector	PLC side connector: L-shaped AFC8503
		PLC side connector: Straight AFC8503S

(Note 1): Prepare a cable (D-sub 9-pin female loose-wire connector) separately for connecting the unit to FP7 control unit or FP7 communication cassette.

#### ■ Options

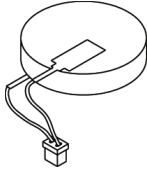
Item name	Appearance	Specifications	Model No.
Battery for GT707 clock		For GT707	1 pc AFPABAT001
Front panel protective sheet	-	For GT707	10 sheets AIG7A07S01

## 1.2 Screen Creating Tool

### 1.2.1 Tools Required for Screen Creation

#### 1. Screen creation tool software

This software is used for creating screens and making various settings.

#### 2. Screen transfer cable (Cable for connecting a PC)

A commercial USB cable is necessary.

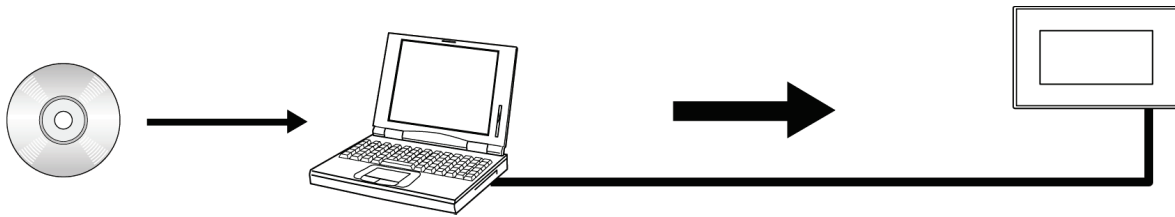

### 1.2.2 Software Usage Environment and Applicable Cables

#### ■ Screen creation tool software Terminal GTWIN Ver.3

Item name	Required OS	Hard disk capacity	Model number
Terminal GTWINVer.3 English edition	Windows® 8.1, Windows® 8, Windows® 7 Windows Vista®	800 MB or more	AIGSGT7EN

(Note 1): As for 64-bit Windows, only Windows® 7, Windows® 8 and Windows® 8.1 are supported. Use 32-bit Windows for Windows Vista®.

#### ■ Screen transfer cable (Cable for connecting a PC)

Appearance	Cable specifications	Length
	USB2.0 cable PC side: A type GT707 side: miniB type	Max. 5 m



# 2

## **Names and Functions of Parts**

## 2.1 Names and Functions of Parts

### 2.1.1 GT707

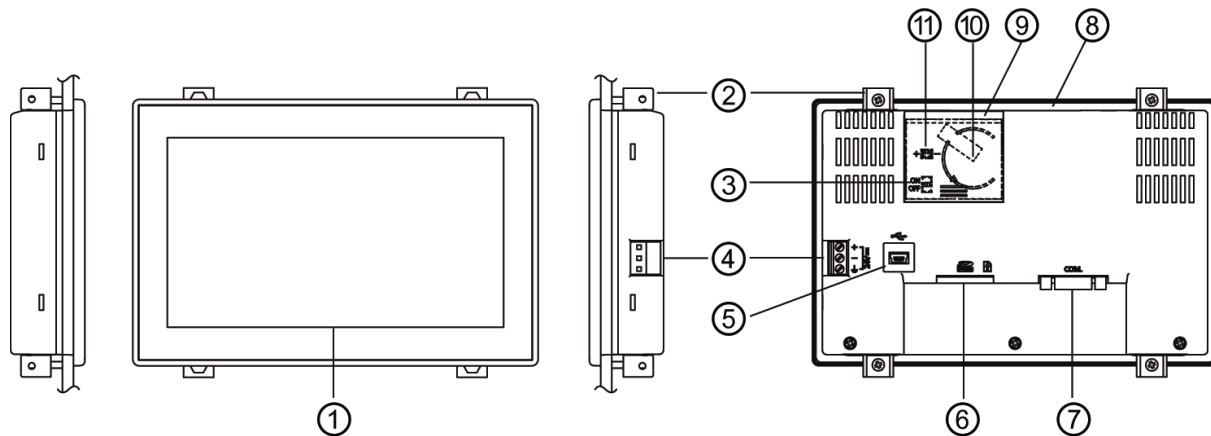

#### ■ Names and functions of parts

No.	Name	Function
①	Touch screen	Various screens are displayed here. Switches can be operated and data entered simply by touching the touch screen. A sheet is affixed to the touch panel to protect it from scratches when shipping. Remove it before using the GT.
②	Attachment fittings	Secure the unit to the installation panel at four points using the fittings and screws provided with the unit.
③	Operation mode setting switches	Switches for setting the operation mode at the time of power-on. Using these switches enables to inhibit to move to the system menu or select the memory clear display.
④	Power supply terminal block (24 V DC)	Power supply terminal for operation and functional ground terminal. Supplies 24 VDC. Be sure to conduct functional ground when there is an influence of noise.
⑤	USB port	Connector for the connection between the unit and a PC when using the screen creation tool software GTWIN. A commercial USB cable is used.
⑥	SD memory card slot	An SD memory card is inserted. SD memory cards can be used for copying screen data and our PLC programs, and used for the logging function, alarm history function and SD recipe function.
⑦	COM port (D-sub 9-pin male connector)	Communication (RS-232C) port for the connection between the unit and an external device such as a PLC and microcomputer board.
⑧	Waterproof packing	This assures that the front panel is waterproof.
⑨	Battery cover	When using a battery for GT707 clock (AFPABAT001) to be separately purchased, open this battery cover to install it. When the battery for the clock is attached, the GT internal clock works even if the power supply is off.
⑩	Mounting position of battery	
⑪	Mounting position of connector for battery	

## 2.1.2 Operation Mode Setting Switches

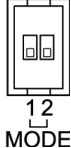
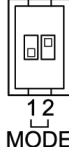
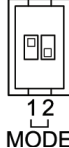
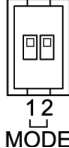
Mode	Normal use (Factory default)		Inhibit system menu shift		Memory clear menu display		Reserved for system (Usage prohibited)	
Switch setting	ON OFF  1 2 MODE		ON OFF  1 2 MODE		ON OFF  1 2 MODE		ON OFF  1 2 MODE	
	SW1	SW2	SW1	SW2	SW1	SW2	SW1	SW2
	OFF	OFF	OFF	ON	ON	OFF	ON	ON

### ■ Operation when selecting the memory clear menu display

- [Clear Memory] menu is displayed by selecting the memory clear menu display and turning the power supply on.
- Press [GT Data] to clear data in the user memory.
- Press [Holding Data] to clear data in the hold memory.
- Press [PLC Backup Data] to clear data backed up using the PLC backup/restore function.
- When memory clear is complete, "Cleared" is displayed.
- For resetting the condition to the normal use, turn off the power supply, change the operation mode setting switches to the normal use mode, and turn on the power supply again.



### ◆ REFERENCE

For information on the data stored in the user memory or hold memory, refer to 5.1.2 Performance Specifications.





# 3

## Installation and Wiring

## 3.1 Installation

---

### 3.1.1 Installation Environment

---

When installing and using the GT series, always make sure the following conditions are observed.

#### ■ Usage conditions

- Ambient temperatures: 0 to +50 °C
- Ambient humidity should be 20 to 85% RH (at 25 °C) and non-condensing.
- Usable altitude: 2000 m above sea level or lower
- For use in pollution degree 2 environment
- Do not use it in the following environments.
  - Direct sunlight, wind and rain. (This product is not designed for outdoor use.)
  - Inflammable or corrosive gas.
  - Excessive airborne dust, metal particles or saline matter.
  - Benzine, paint thinner, alcohol or other organic solvents or strong alkaline solutions such as ammonia or caustic soda.
  - Direct vibration, shock or places always exposed to drop of water.

(This unit is warranted by IP65 for panel mounting, however, this applies to initial values.)

- Influence from power transmission lines, high voltage equipment, power cables, power equipment, radio transmitters, or any other equipment that would generate high switching surges. (100mm or more)

#### ■ Static electricity

- Do not touch connector pins directly to prevent static electricity from causing damage.
- Always rid yourself of any static electricity before handling this product.
- If excessive static electricity is applied to the panel surface, the LCD panel may be damaged.

### 3.1.2 Restriction According to Mounting Directions

If the unit is used in a vertical orientation or installed in a horizontal orientation, note that the ambient usage temperature should be as below.

Model name	Condition	Ambient temperature
GT707	Horizontally installed	0 to 50 °C
	Vertically used	

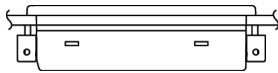

Horizontally installed

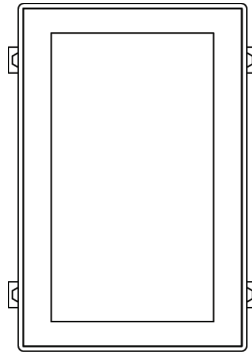

Vertically used

### 3.1.3 Installation Space

#### ■ Applicable panel thickness

A panel with a thickness of 1.0 to 5.0 mm should be used. Use a panel that is strong enough not to be warped.

#### ■ Clearance when the GT is installed

When installing the GT unit, if other parts are being installed to the panel or cables are being wired to it, we recommend providing a clearance around the GT unit. This prevents cables from being damaged, and facilitates the installation work. Also, make sure that the slits in the main unit are never obstructed.

Model name	Clearance	Clearance on the surface to connect the screen transfer cable
GT707	30 mm or more (50 mm or more recommended)	60 mm

### 3.1.4 Mounting Screws

- The GT unit is secured to the installation panel using the fittings and screws (4 sets/per unit) provided with the unit.
- Commercial M3 screws (length: 16 mm) can be also used. Using screws that do not comply with the specifications will cause failures such as decrease of water-proof property.

### 3.1.5 GT707 Installation Method

---

Secure the GT to the installation panel using the fittings and screws (4 sets/per unit) provided with the unit.



#### ◆ PROCEDURE

---

1. Place the GT unit in the installation panel.
2. Insert the fittings into the grooves of the GT unit, and slide them to be fixed.
3. Tighten the screws [M3 (Length: 16 mm)] to secure the GT unit to the installation panel.

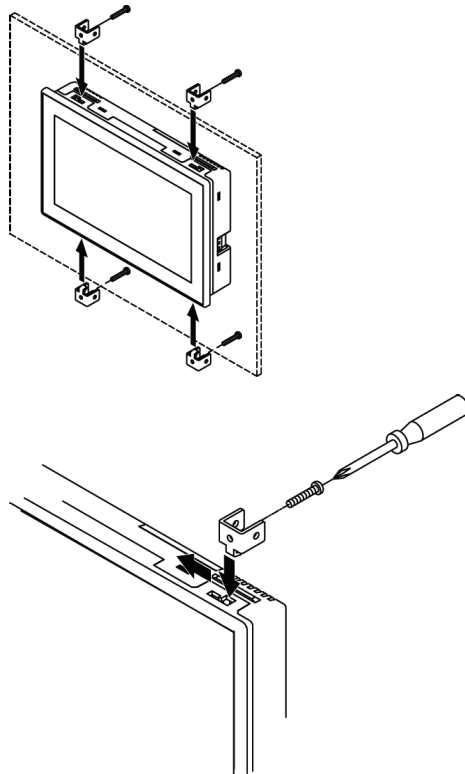

(Enlarged view)



#### ◆ NOTES

---

- The cross slot screwdriver of #2 must be used.
- The tightening torque of the screw [M3 (Length: 16 mm)] should be 0.2 to 0.3 N·m. Tightening the screws too hard can cause deformation of the front panel, so that the touch switches will not function properly.

### 3.1.6 Installing in Vertical Orientation

---

- The GT series can be installed upright. The power supply connector is placed on the top side as illustrated below.
- Select the vertical type when selecting a GT model in GTWIN.

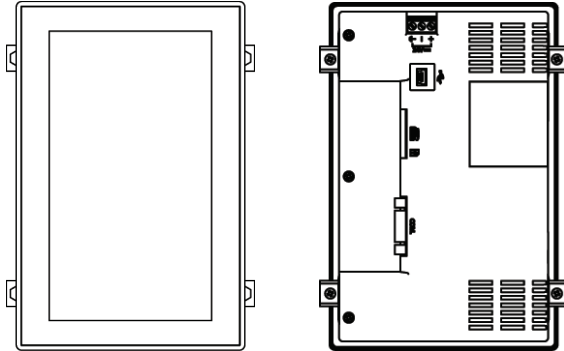

## 3.2 Wiring the Power Supply

---

### 3.2.1 Precautions on Wiring

---

- Perform wiring and placement of the cable so that there is no impression of external noise on the cable and no induction.
- This product conforms to EN61131-2 for the European EMC Directive (EMC Directive 2004/108/EC). The conformity conditions are as below.
  - 1) Use shielded wires for distribution cables.
  - 2) The GT unit should be grounded.

### 3.2.2 Wiring the Power Supply

---

#### ■ Use twisted wiring for the power supply

In order to minimize influence from noise, the wiring for the power supply should be twisted.

#### ■ Insulate the power supply inside a protective circuit

- In order to protect the unit against abnormal voltage from the power supply line, the power supply should be an insulated type, and should be enclosed within a protective circuit.
- The unit has sufficient noise immunity against the noise generated on the power line. However, it is recommended to take measures for reducing noise such as using an isolating transformer before supplying the power. And it is recommended to take measures such as installing a ferrite core.
- If a power supply device without an internal protective circuit is being used, power should always be supplied to the GT series through a fuse or a similar protective device. Directly applying an abnormal voltage to the unit may cause the damage to the internal circuit.

#### ■ Keep the power supply voltage within the operating voltage range

Rated voltage	Operating voltage range
24 V DC	21.6 to 26.4 V DC

#### ■ Keep the power supply wiring separate

Wiring to the GT series, PLC, and other power equipment should have separate wiring systems.

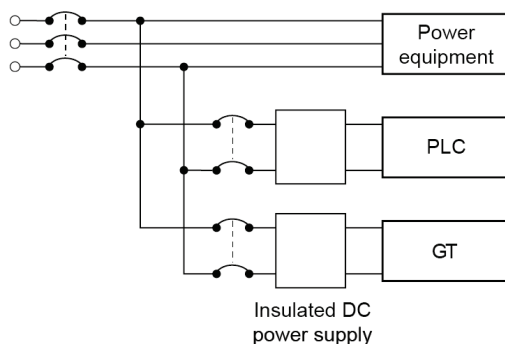

### 3.2.3 Wiring of Terminal Block

#### ■ Layout of terminal block for power supply

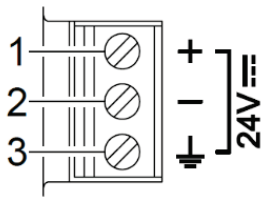

Pin No.	Function
1	+24 V
2	0 V
3	Functional ground

#### ■ Suitable wires (strand wire)

Size	Nominal cross-sectional area	Rated temperature	Tightening torque
AWG24 to 16	0.2 to 1.25 mm <sup>2</sup>	75 °C or more	0.5 to 0.55 N·m

#### ■ Wiring method

- When removing the wire's insulation, be careful not to scratch the core wire.
- Do not twist the wires to connect them.
- Do not solder the wires to connect them. The solder may break due to vibration.
- For tightening the terminal block, use a flat-blade screwdriver with a blade size of 0.5 x 3 mm.
- After wiring, make sure stress is not applied to the wire.
- In the terminal block socket construction, if the wire is fastened upon counter-clockwise rotation of the screw, the connection is faulty. Disconnect the wire, check the terminal hole, and then re-connect the wire.

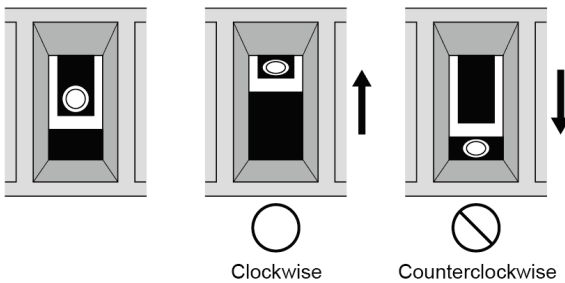

#### ◆ PROCEDURE

1. Remove a portion of the wire's insulation.

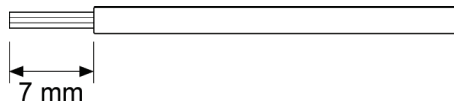

2. Insert the wire into the terminal block until it contacts the back side.
3. Tighten the screw clockwise to fix the wire in place.

### 3.2.4 Grounding

#### Be sure to ground when the influence of noise is great

The unit is tolerant against noise in normal environments, but if the environment is particularly susceptible to noise, please ground.

#### Use dedicated grounding

- Make the grounding point as close as possible to the GT and keep the distance of the grounding wire short.
- Sharing the ground with another device may have an adverse effect. Therefore, be sure that grounding is dedicated.

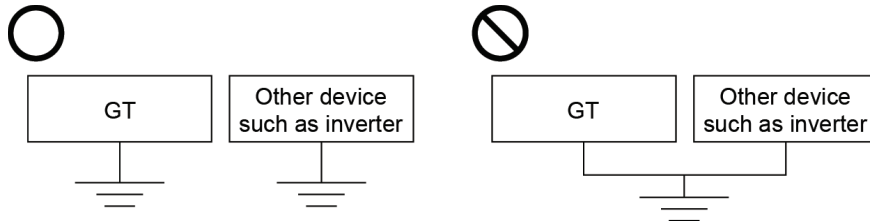

#### NOTES

- Conversely, depending on your environment, grounding may cause a problem.
- Since the power line of the GT unit is connected to a functional earth via electronic parts, the electronic parts may become damaged if there is an abnormal potential between the power line and the physical ground.

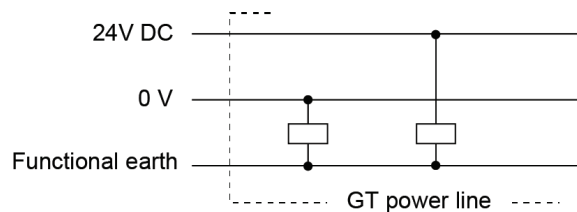



## 3.3 Wiring of COM Port

### 3.3.1 Specifications of COM Port

#### ■ Specifications of GT707 COM port

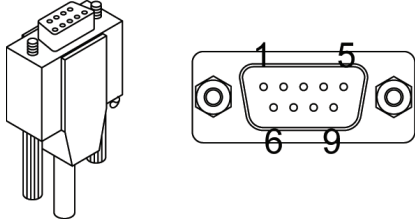

Pin No.	Name	Abbr.	Signal direction
1	N.C.	—	—
2	RS-232C Receive Data	RD	External devices to GT
3	RS-232C Send Data	SD	GT to External devices
4	N.C.	—	—
5	Signal Ground	SG	—
6	N.C.	—	—
7	RS-232C Request to Send	RS	GT to External devices
8	RS-232C Clear to Send	CS	External devices to GT
9	N.C.	—	—

(Note 1): Do not connect anything to N.C..

(Note 2): Data cannot be sent unless the CS signal (clear to send) turns ON when selecting "System Setting" > "GT Configuration" > "GT Communication Parameters" from the GTWIN menu and setting "CS/RS Control" to "On". When using the general-purpose serial communication. When using with a three-wire port, short-circuit the pins RS and CS or set "CS/RS Control" to "Off".

### 3.3.2 Wiring Example of COM Port

■ **Wiring example (Between FP series COM port and GT707)**

- Use a loose wire for the connection on the PLC side.
- It can be used in combination with our PLC equipped with a RS-232C interface.

**Applicable PLC models**

Model	Usable combination
FP0R	Control unit (Type equipped with RS-232C port) C10CRS / C10CRM / C14CRS / C14CRM / C16CT / C16CP / C32CT / C32CP / T32CT / T32CP / F32CT / F32CP
FP-X	Usable in combination with each control unit and the following FP-X communication cassettes. AFPX-COM1 / AFPX-COM2 / AFPX-COM4 / AFPX-COM5
FPΣ	Usable in combination with each control unit and the following FPΣ communication cassettes. AFPG801 / AFPG802 / AFPG806
FP7	Usable in combination with each FP7 CPU unit or FP7 serial communication unit and the following FP7 communication cassettes. AFP7CCS1 / AFP7CCS2 / AFP7CCS1M1

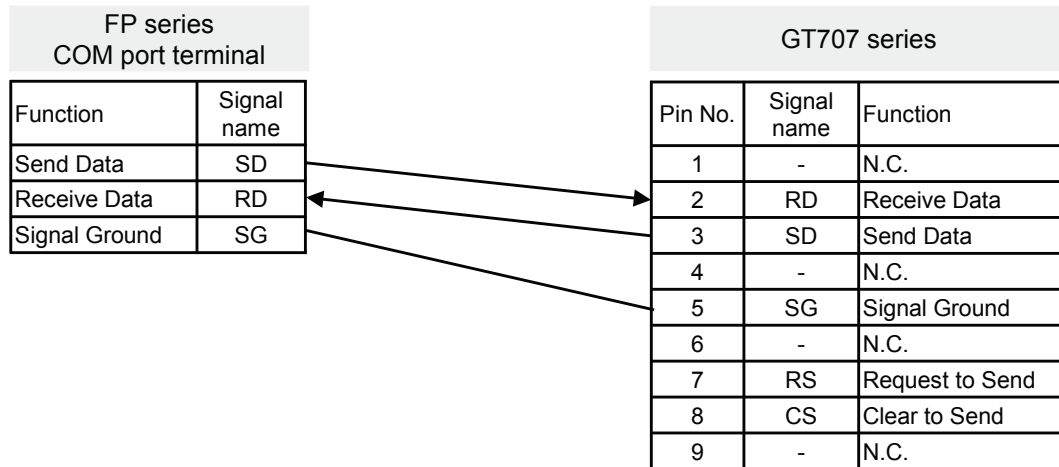

■ **Wiring example (Between FP series PLC TOOL port and GT707) (1)**

- Use the mini-DIN 5-pin round connector for the connection on the FP-series PLC TOOL port side. The following figure shows the connection with the cable AFC8503/AFC8503S.
- The FG terminals of PLC and GT707 are connected.

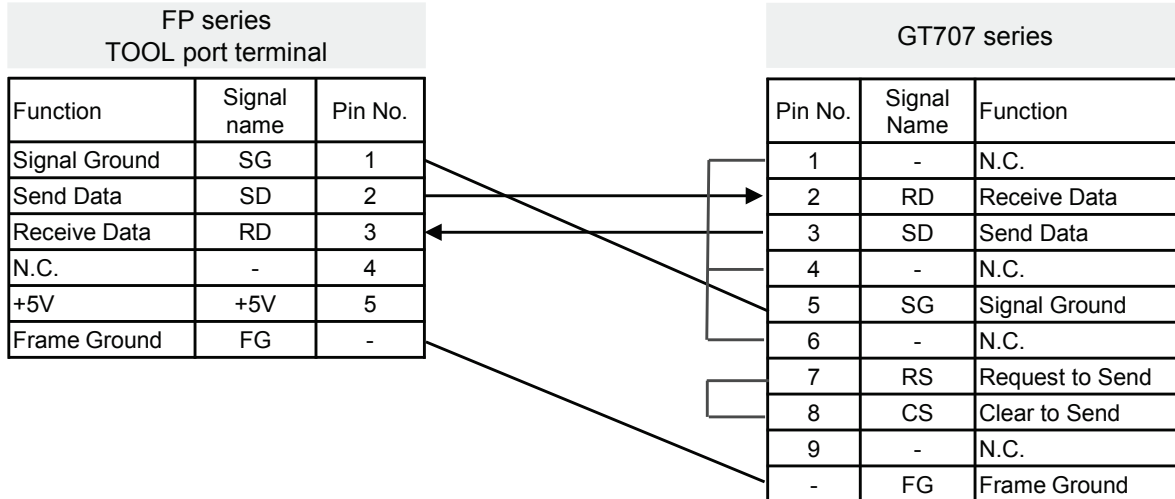

■ **Wiring example (Between FP series PLC TOOL port and GT707) (2)**

- Use the mini-DIN 5-pin round connector for the connection on the FP-series PLC TOOL port side.
- The following figure shows the connection diagram with cables you construct. The following connections are not necessary; the connections of signal lines RS/CS on GT707 side (Nos. 7 and 8), the connections of ER/DR/CD (Nos. 1, 4, and 6), the connection of FG.

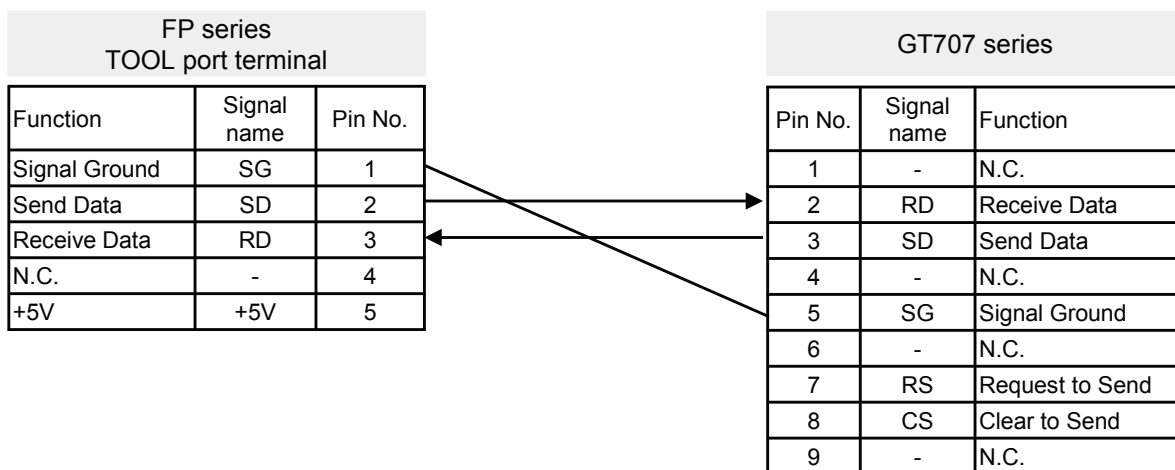

## 3.4 Communication with PLC

---

### 3.4.1 Automatic Communication Settings Function

---

#### ■ Overview of Automatic Communication Settings Function

- After turning on the power supply, if there is not response from the PLC connected to the GT, the GT switches to the automatic setting mode for the communication conditions.
- In the automatic setting mode, commands are sent to the PLC while changing the communication conditions in the sequence shown below. The GT, in automatic setting mode, repeats the operation until there is a response from the PLC.
- The repetition interval is set as "Wait" in the "Communication Error Handling" dialog box displayed by clicking the "Setup" button for "Communication Error Handling" selected from Tool software GTWIN menu "System Setting" > "GT Configuration" > "GT Communication Parameters".



- |   |  |
|---|--|
| ① 9600 bps, 8 btis, odd parity, 1 stop bit  | ④ 57600 bps, 8 bits, odd parity, 1 stop bit                    |
| ② 19200 bps, 8 btis, odd parity, 1 stop bit | ⑤ 115200 bps, 8 btis, odd parity, 1 stop bit                   |
| ③ 38400 bps, 8 btis, odd parity, 1 stop bit | ⑥ Communication conditions set in GTWIN Configuration settings |

(Note): The above order is for FP series PLC. The pattern of the automatic communication settings varies depending on PLC models.

#### ■ Conditions when the automatic settings mode is in effect

If communication is attempted the specified number of times and there is no response from the PLC, the GT goes into the automatic settings mode. The number of retries is set in the "Communication Error Handling" dialog box displayed by clicking the "Setup" button for "Communication Error Handling" selected from Tool software GTWIN menu "System Setting" > "GT Configuration" > "GT Communication Parameters".

#### ■ Automatically set communication conditions

In the automatic settings mode, if there is a response from the PLC, subsequent communication is carried out under conditions matching the response. The main unit configuration settings are not updated, however, even if the communication parameters are different from those of the main unit configuration settings.



#### ◆ NOTES

- An error response from the PLC is taken as a response, and the GT does not go into the automatic settings mode.

- The GT cannot communicate with PLC unless the target usage of the RS-232C port is set to "Computer Link". Always set the setting on the PLC side to match "Computer Link".

### 3.4.2 Through Function

---

- GT series is equipped with the through function which passes the communication received from the USB port for our PLC through the COM port.
- When the tool software for the FP series/FP7 series is booted on a PC connected to the GT series, PLC programs can be edited or monitored through the GT series.
- The through function is always enabled when the PLC type for GT is set to Panasonic PLC. It can be used in combination with Panasonic PLC equipped with an interface.

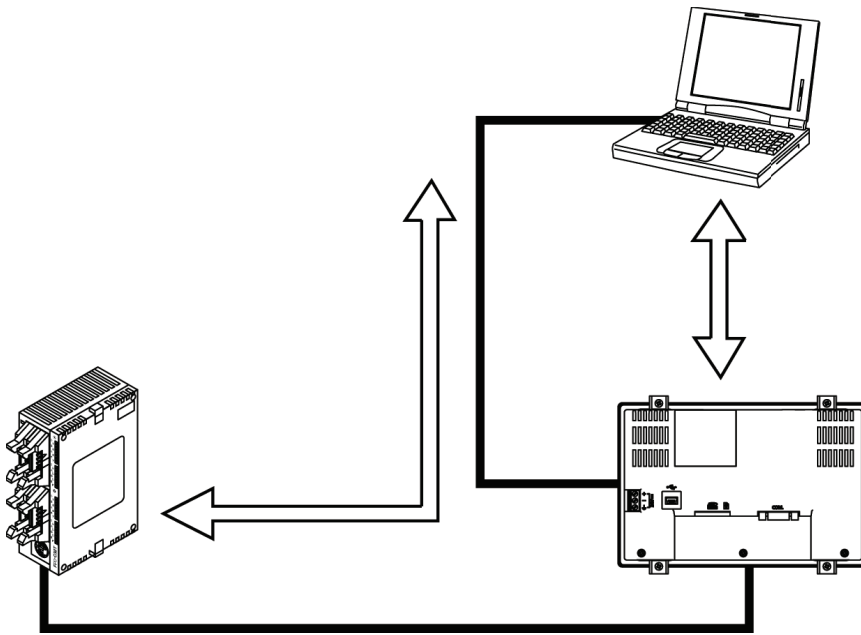

#### NOTES

---

- The system should be set up so that the Timeout period in the FP series software (A) is larger than the waiting time for communication retries of the GT COM port (B), meaning  $(A) > (B)$ . If the system is set up so that  $A = B$  or  $A < B$ , the through function will not work properly.

## 3.5 Battery for Clock

### 3.5.1 Battery for Clock

- For using the clock function built-in the GT, a battery for the clock should be mounted. Even when the power supply is off, the clock works.

#### ■ Battery for clock

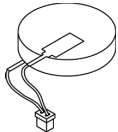
Item name	Appearance	Specifications		Model No.
Battery for GT707 clock		For GT707	1 pc	AFPABAT001



#### ◆ NOTES

When using the battery for clock, attach the battery before the power supply is turned on.

### 3.5.2 How to Mount Battery for Clock



#### ◆ PROCEDURE

1. Slide and remove the battery cover.
2. Insert the connector to make the red line be the (+) side.

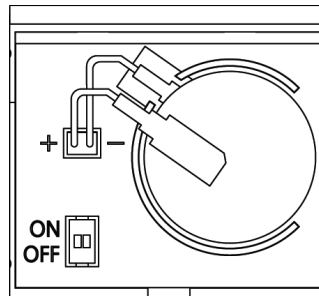
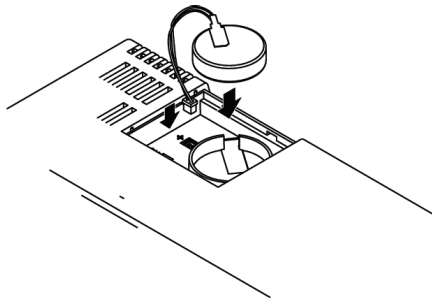

3. Set the battery in the circular frame.
4. Attach the battery cover.

### 3.5.3 Lifetime and Time for Replacement of Battery for Clock

---

#### ■ Lifetime of battery for clock

Battery life, when operating at a normal temperature (25 °C), a normal humidity (65% RH), is as follows.

GT model	Life
GT707	Approx. 5 years

#### ■ Detection of battery error (1) Battery mark

- Battery life is detected when the power of the GT turns OFF and ON. When clock data is not held, a battery mark can be displayed on the screen. Select "System Setting" > "GT Configuration" > "Basic Setup", and check "Battery Error Display".
- The battery mark is displayed at the bottom right of the screen.

#### ■ Detection of battery error (2) Operation of BAT flag

- Battery life is detected when the power of the GT turns OFF and ON. When clock data is not held, the BAT flag in the basic communication area map turns ON. As necessary, create a program for reporting the error to outside on the PLC side.
- The BAT flag is allocated to the third word of the basic communication area bit device, bit number 1 (Default is the internal relay R21).
- The BAT flag is activated regardless of the setting of "Battery Error Display".
- Although the BAT flag goes on once when the power supply is turned ON for the first time, that is not an error.

#### ■ How to Replace Battery

- The procedure for replacing the battery for GT707 clock is as follows.



#### ◆ PROCEDURE

---

1. Turn off the power.
2. Slide the cover and remove.
3. Remove the used battery.
4. Attach a new battery.
5. Turn on the power, and reset the clock.



#### ◆ NOTES

---

- Reset the clock data after replacing the battery.
- If the battery life is expired while the power is continuously ON, both the BAT flag of the basic communication area and battery mark cannot detect it.





# 4

## Troubleshooting

## 4.1 What to Do If an Error Occurs

Problem	Cause	Solution
Screen is blank.	Power is not on.	Check the power within the specifications is supplied.
	The power voltage may be low.	Check the capacity of the power supply unit if it is enough for the GT's power consumption.
	When only lamp and message parts are configured to the base screen, the value of substitute reference device value does not exist in substitute data.	Check the address of the substitute reference device and the device values on the PLC side.
	The backlight is off due to the [Backlight Control (Auto-Off)] setting in the [Setup] of the GT configuration settings in GTWIN.	Touching any area of the screen lights that area. If a switch part is set on the touched area, the area will not light even if touched. To change the setting, change the setting of "Backlight Control (Auto-Off)".
Error code [ER****] appears at the top right of the screen.	An error has occurred in communication between the GT and an external device (e.g. PLC).	Refer to <4.2 Error Codes and How to Handle Them>.
Screen displays [No Screen data].	There is no screen data in the GT.	Select "Communication" in the GTWIN menu and transfer screen data.
Screen displays [Screen No. Error].	Screen settings from the PLC, the GT's switch part or the auto-paging indicate an unregistered screen number.	Create and register screen content or specify the correct screen number.
	When bringing up the keyboard screen during data input, an unregistered keyboard screen number was specified.	Create and register a keyboard screen or specify the correct keyboard screen number.
	GT configuration data and keyboard screen data exist in the GT, but there is no base screen data.	Transfer base screen data from GTWIN.
Screen displays [Memory is Full]	The total capacity of transferred base screen data exceeds the memory capacity of the GT.	Delete part of the base screen data so that the capacity doesn't exceed the total capacity. Data capacity can be checked by going to [View (V)] > [Total Memory Usage] on GTWIN menu bar. When the data capacity is not over the limit, invalid data could possibly be remaining in the GT. When transferring data, do so after deleting the screen.
An unspecified screen appeared/there is trouble when switching screens.	The screen specification in the PLC screen setting, the GT switch part or the auto-paging is wrong.	Specify a correct screen number.
	The startup screen is specified in the GT configuration settings (GTWIN).	Check the start-up screen setting for the GT configuration settings in GTWIN. Delete unnecessary settings and re-transfer configuration data.
	An erroneous device or value is specified in the first word of the basic communication area word device.	Check the device content specified on the PLC side in the first word of the basic communication area. Make a program not to overwrite the basic communication area by other applications.

Problem	Cause	Solution
Screen doesn't switch.	No screen number has been written to the screen setting area (the first word in the basic communication area word device) from the PLC.	Specify a correct screen number.
	The screen number to which you are attempting to switch has already been written from the PLC to the screen setting area (the first word in the basic communication area word device).	For the function switch, use the operation mode "Value Set" to change the contents of the first word in the basic communication area.
Screen is dim.	The backlight brightness in the system menu is set low.	Adjust the brightness from the system menu.
	The backlight brightness of the basic communication area may be set low.	Refer to the basic communication area map and check the operation of the bit allocated to PLC.
	The backlight is off by the Backlight Control (Auto Off) function.	Touching any area of the screen lights that area. If a switch part is set on the touched area, the area will not light even if touched. To change the setting, change the setting of "Backlight Control (Auto-Off)".
	The backlight brightness of GTWIN Configuration may be set low.	Select "System Setting" > "GT Configuration" > "Basic Setup", and change "Backlight Brightness Setting".
Backlight goes off too quickly.	The setting of "Backlight Control (Auto-Off)" is too short.	Change the set time of "Backlight Control (Auto-Off)".
Date/time display is incorrect. (when using the GT's internal clock)	The GT's internal clock is incorrect.	Adjust the clock from the system menu.
	A battery is not mounted.	Attach a battery.
	The battery has run down.	Replace the battery.
Date/time display is incorrect. (when using the PLC's calendar timer)	The PLC's internal calendar timer used as a reference is incorrect.	Adjust by rewriting the value in the PLC's internal calendar timer.
Touch panel doesn't work.	Valid conditions have been set for the switch part, but those conditions have not been met.	Check that the device status conditions on the PLC side are valid.
No operating sounds are heard when the touch panel is pressed.	The [SW Sound] setting under [Option] in the switch parts attribute is set to [Off].	Change the setting to [On].
	"Enable Touch Sound" in [Basic Setup] of GT Configuration is not checked.	Check "Enable Touch Sound".

Problem	Cause	Solution
Buzzer sounds continuously.	Bit F of the first word in the basic communication area bit device is set to ON.	Refer to the basic communication area map and check the operation of the bit allocated to PLC.
Backlight color changes/flashes.	The backlight flashing flag or the backlight enable flag of the basic communication area may be ON.	
Data cannot be transferred from GTWIN.	A USB cable is not connected.	Confirm that the USB cable is firmly connected.
	The network type in the communication settings has been set to "RS-232C".	Select "Communication" > "Communication Settings" from the GWIN menu, and set "Network type" to "USB(GT)".
	A USB driver is not installed.	Refer to the installation guide and install the USB driver for GT.
Screen is blank. (power supply and substitution settings noted above do not apply)	An error has occurred in the GT system.	<p>1) After confirming the safety of the device, etc., turn off the power supply and then turn it on again. The GT CPU will be reset.</p> <p style="text-align: center;">↓</p> <p>2) Set the operation mode setting switch 1 to ON, turn on the power supply, and clear "Holding Data" and "GT Data".</p> <p>3) Reset the operation mode setting switch to OFF and turn on the power supply.</p> <p>NOTE: All screen data, setting files and hold data will be cleared. Make sure screen data and setting files have been backed up. However, hold data cannot be backed up.</p>
An incorrect screen is displayed. (error codes and erroneous date and time items noted above do not apply)		
Switch doesn't work. (grid and validity settings noted above are correct)		
Buzzer sounds continuously.		

■ **Operation security function**

<b>Problem</b>	<b>Cause</b>	<b>Solution</b>
"Incorrect password." Is displayed on the login screen.	An unregistered password was entered.	Enter the registered password.
"Incorrect password." Is displayed on the password change screen.	An incorrect password was entered in the Current password field.	Enter the registered password correctly.
"Please verify your password again." is displayed on the password change screen.	The entered New password and Confirm password are different.	Enter the same password in the New password and Confirm password fields.
"Use another password." is displayed on the password change screen.	The password that has been already registered is tried to be registered.	Enter an unregistered new password.
"Password setting incomplete." is displayed on the password change screen.	There are items that are not entered.	Enter all items.
"Your password cannot be deleted." is displayed on the password management screen.	Your password was tried to be deleted.	Your password cannot be deleted. If you want to delete it, select "System Setting" > "Operation Security Password" from the GTWIN menu and change the setting content.
"Your level cannot be changed." is displayed on the password management screen.	Your level was tried to be changed.	Your security level cannot be changed. If you want to change it, select "System Setting" > "Operation Security Password" from the GTWIN menu and change the setting content.

■ **When using an SD memory card**

Data may be erased or the SD memory card may be damaged during the operation. Take measures for the situations as below.

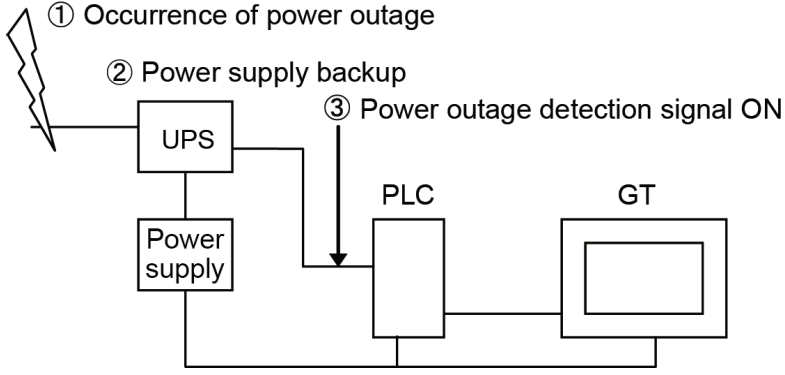
Problem	Measures
Data in RAM (Record area for logging) is lost.	<p>Transmitting GT configuration setting file using the logging function clears the information on the RAM. Save all the data remained in the log before transmission.</p> <p>When data cannot be saved in the SD memory card, the data beginning with the chronologically oldest data will be overwritten if the record area for logging is full. Make the setting of the notice device for the case that the SD card free space is less than the specified size.</p>
SD memory card is damaged and data cannot be read because SD memory card was ejected during save.	<p>Stop the logging of data. Eject the SD memory card after turning on the setting for stopping the trigger occurrence for all logging files in the record area control. (Activate the setting for stopping the trigger occurrence with switch parts, etc.)</p> <p>Set not to save in the SD memory card. Turn on the control device for stopping write to the SD memory card, and then eject the card.</p>
SD memory card is damaged by power discontinuity due to power failure and data cannot be read.	<p>A UPS (Uninterruptible power source) is used. When using a UPS, the power is supplied to the PLC and GT both from the UPS, and the signal for logging stop/file creation is sent to the GT from the PLC using the power failure alarm signal that is input into the PLC as a trigger. (See figure below.)</p> <p>① Occurrence of power outage</p> <p>② Power supply backup</p> <p>③ Power outage detection signal ON</p>  <p>④ Logging stops</p>

## 4.2 Error Codes and How to Handle Them

### 4.2.1 About Error Codes

- When an error occurs in the GT series, an error code displays at the top right of the screen.
- There are two types of error codes, GT707 series error codes and PLC error codes.

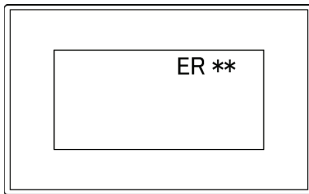

### 4.2.2 GT707 Series Error Codes

#### ■ List of error codes

Code No.	Content	Cause and solution
**00FF	Time up error	The connection between the GT and PLC may not be correct. Check the wiring of the connection cable and check for disconnection. Also, there may be a temporary error due to noise, etc. Re-supply power to the PLC and GT.
**0100	Keyboard screen data parts digit error	Check if the digit of the data parts on the keyboard screen has been set correctly.
**0101	Alarm history error	When updating the alarm history display is stopped, alarm history data displayed on the GT's screen has been updated within the memory. Once the stop of display update is cancelled, new data is displayed.
**0102	True Type font file transfer error	Screen data is not transferred correctly. Re-transfer data after deleting all data.
**0500	Tool setting error	The device that cannot be used is specified for the data. Check if the used device is correct. (e.g. the word device is set in the bit area.)
**1000	SD memory card not inserted	An SD memory card is not inserted into the slot properly. Check the SD memory card slot.
**1001	SD memory card writing error	Data cannot be written into the SD memory card. Check whether the SD memory card is not write-protected.
**1002	SD memory card memory full	Data cannot be written as the memory of the SD memory card has been exhausted. Delete some data in the SD memory card or prepare a new SD memory card.
**1003	SD memory card reading error	The data in the SD memory card cannot be read. Check whether the saved data in the SD memory card is not damaged with a PC.
**1004	SD memory card data error	The data loaded from a SD memory card does not match the GT type. Read the data in the SD memory card with GTWIN, and check whether it is not damaged.
**1005	SD memory card saved file name error	The file name to be saved to the SD memory card from the GT is not specified properly. Specify the file name properly.

Code No.	Content	Cause and solution
**1006	SD memory card recognition error	The SD memory card cannot be recognized. Check the SD memory card used.
**1020	PLC model unmatched error	Check if the PLC program for transfer matches the destination PLC.
**1021	PLC model unsupported error	The selected PLC model is not supported. Confirm the PLC model.
**1022	Password protection error	Incorrect passwords were successively input three times . Turn on the power supply again, and enter the correct password.
		The upload protection has been set for the PLC.
		The number of digits was changed when setting a new password with the FP monitor function. Cancel the password setting first to change the number of digits.
**1023	Master memory installation error	A master memory is installed in the PLC (FP-X). Programs cannot be transferred to the PLC with the master memory from a SD memory card.
**1024	Program memory shortage	Program memory shortage in the destination PLC. Decrease the program size using the PLC tool.
**1025	General-purpose memory shortage	General-purpose memory shortage in the destination PLC.
**1027	Remote mode error	The PLC (FP2/FP2SH) is set to the RUN mode. Change to the REMOTE mode or PROG. mode.
**102D	Forced operation error	Check if a device that cannot be forcibly operated in the PROG. mode has been forcibly turned on or off.
**1040	The record area for logging was overwritten.	Check if an SD memory card is inserted.
**1041		Data cannot be written into the SD memory card. Check whether the SD memory card is not write-protected.
**1042		The memory of the SD memory card is full. Delete some data in the SD memory card or prepare a new SD memory card.
**1044		The setting to stop writing to SD memory card has been set. Cancel the writing stop setting.
**1043	SD memory card writing error	The setting to stop writing to SD memory card has been set. Cancel the writing stop setting.
**1045	The record area for logging cannot be reserved in the RAM.	Transfer all data.
**10A0	ROM write error	The firmware file loaded from the SD card is damaged. Recreate the file in the SD card.
**1060	Index register value error	The device value for index modifier is out of the setting range. Check the setting value.
**1080	Start time device value error	The value at the start of the line graph function is out of the setting range. Check the setting value.
**E000	Send data overflow	Communication data to PLC overflowed. Some data could not be sent because of this. Check if the GT communicates with the PLC properly.
**F000	User's memory error	The memory for saving screen data may be damaged. Please contact your dealer.
**F100	OS/System error	It is activated on the OS/system before updating as an error occurred or the power was cut during the update of the OS/system. Reexecute the transfer or copy of data from SD to GT performed immediately before.



### 4.2.3 When Connected to a FP Series PLC

Error codes which are sent from the PLC are listed in the table below.

For details, refer to the table of MEWTOCOL-COM communication errors in PLC user's manuals.

■ List of error codes

Code No.	Content	Cause and solution
ER0021	Data error A data error occurred during communication.	Settings of the communication condition may be wrong. Check the PLC and GT baud rate and transfer format. Also, there may be a temporary error due to noise, etc. Re-supply power to the PLC and GT.
ER0022	Overrun error The PLC isn't receiving data.	The CPU unit's reception buffer is overflowing. There may be an error in the PLC. Re-supply power to the PLC and GT.
ER0040	BCC error A data error occurred during communication.	There may be a temporary error due to noise, etc or error in the PLC. Re-supply power to the PLC and GT.
ER0041	Format error The PLC has been sent a command that doesn't match the protocol.	There may be a temporary error due to noise, etc or error in the PLC. Re-supply power to the PLC and GT.
ER0042	NOT support error The GT has sent a non-supported command to the PLC.	There may be a temporary error due to noise, etc or error in the PLC. Re-supply power to the PLC and GT.
ER0053	Busy error The PLC is currently processing another command.	A large amount of data is being communicated with another RS-232C port on the PLC. Wait until the error is gone.
ER0060	Parameter error	The specified parameter does not exist, or it cannot be used.
ER0061	Data error There is an error in the register or relay number.	A register or relay number which doesn't exist in the PLC was specified during screen creation using GTWIN. Correct the output device being used with the part, or the transfer of clock data to an external device.

## 4.2.4 When Performing General-purpose Serial Communication

---

### ■ List of error codes

Error code	Error name	Measures
**0000	BCC error	The value of BCC may be incorrect. Check if there is no calculation mistake.
**0001	Format error	A command format may be incorrect. Check if it is correct.
**0002	NOT support error	A command used is not supported with the version of the GT. Upgrade the version of the GT, or use another command.
**0003	Address error	The address specified does not exist in the GT. Check the address of the sent command.
**0004	Receive buffer overflow	The sent command exceeds the receivable number of bytes. Check the number of bytes of the sent command.
**0005	Requested overflow	The sent readout command exceeds the number of bytes that can send back. Check the number of the read words.
**0006	Data error	The communication condition for the GT may be unmatched with the condition for a destination device. Check the communication conditions.
**0007	Data write inhibit error	A command for the address that writing is not available was sent. Check the address of the sent command.

# 5

## Specifications

## 5.1 GT707 Specifications

### 5.1.1 General Specifications

Item	Specifications
Rated voltage	24V DC
Operating voltage range	21.6 to 26.4V DC
Power consumption	6 W or less (250 mA or less)
Operating ambient temperature	0 to +50 °C
Operating ambient humidity	20 to 85% RH (at 25 °C), non-condensing
Storage ambient temperature	-20 to +60 °C
Storage ambient humidity	10 to 85% RH (at 25 °C), non-condensing
Breakdown voltage	Between [power supply terminals] and [case] 500 V AC for 1 minute, Cutoff current: 10 mA (at default setting)
Insulation resistance	Between [power supply terminals] and [case] 100 M $\Omega$ or more, 500 V DC, measured with megohmmeter (at default setting)
Vibration resistance	Conforms to IEC61131-2. 5 to 8.4 Hz, 3.5-mm single amplitude 8.4 to 150 Hz, Acceleration 9.8 m/s <sup>2</sup> 10 sweeps each in X, Y and Z directions (1 octave/min)
Shock resistance	Conforms to IEC61131-2. 147 m/s <sup>2</sup> , 3 times on X, Y and Z directions
EC Directive applicable	EN61131-2 (EMC Directive)
Noise immunity	1,000 V [P-P] or more, Pulse width 50 ns, 1 $\mu$ s between power supply terminals (based on in-house measurements) (Note 1)
Electrostatic discharge resistance	4 kV (Contact discharge)
Protective construction	IP65 (Initial value, evaluated by us) Dustproof and drip-proof from front panel only (packing used on panel contact surface)
Weight	Approx. 360g

(Note 1): When using our exclusive cable.

## 5.1.2 Performance Specifications

Item		Specifications
Display (Note 1)	Display device	TFT color LCD
	Number of dots	800 (W) x 480 (H) dots
	Displayable area	153.8 (W) x 85.6 (H) mm
	Backlight	LED backlight
	Backlight brightness	Can be adjusted on the menu screen, GTWIN configuration settings or PLC. (There are some minor variations in the backlight brightness.)
Touch switches	Touch switch	Analog touch switch (resistive film type)
	Touch switch operation	0.8 N or less
	Life	1 million times or more (at 25 °C) (Note 2)
Memory	User Memory	GT data (the following data) is stored. Base screen + Keyboard screen + Login screen: 38 Mbytes Bitmap + Data in blank space area: 38 Mbytes
	Hold memory (Note 3)	Hold data (the following data) is stored. Alarm history + Line graph sampling: 27.5 kbytes Logging data of Logging function: 64 kbytes Hold GT Device: 2048 + 255 words Hold PLC Device: 24 words
Battery (Note 4)	Application	For driving the GT internal clock
	Life	Approx. 5 years (at 25 °C)

(Note 1): On the LCD panel, bright spots ( points always lit) or black spots (points always unlit) may appear, or the uneven brightness, flickers or crosstalk (appearance of unintended shades in the area no graphic or part is arranged) may occur depending on the operating conditions. Note that these phenomena are resulted from the basic characteristics of LCD panel not defects or failures of the product.

(Note 2): The touch position may shift due to aging variation. If the touch position has shifted greatly, please adjust it.

(Note 3): Data is held while the power supply is off without battery .

(Note 4): Please purchase a battery separately. The battery life is the value when no power at all is supplied. The actual lifetime may be shorter according to the condition of use.

### 5.1.3 Function Specifications

Item	Specifications
Displayable fonts	True Type (GTWN): 10 to 240 dots Windows(R): 10 to 240 dots
Character types	Simplified Chinese, Traditional Chinese characters, Japanese, English, Korean, German, French, Italian, Spanish, Turkish, Russian and Vietnamese can be displayed.
Number of registerable screens	Approx. 230 screens (Note 1)
Registerable screen number	Base screen: No. 0 to 3FF Keyboard screen: No. 0 to 7 Login screen: No. 0 to F
Graphics	Straight lines, Continuous straight lines, Squares, Circles, Arcs, Curves, Fan shapes, Polygons, Fill, Bitmap
Types of parts	Lamp switch Data Bar graph Clock (Note 2), (Note 3) Line graph Alarm list Keyboard
Main functions (Note 4)	Recipe SD recipe Flow display Write device Multi-language exchange Operation security Logging function
Through function	Communication between our PLC and a computer is available by connecting the computer to USB port and the PLC to COM port.
Copy function	Screen data can be copied with a SD memory card. Programs of Panasonic FP series PLCs can be uploaded/downloaded via SD memory cards.
PLC backup/restore function (Note 5)	Programs and registers of a Panasonic FP series PLC connected to the COM port can be backed up in the GT internal memory.
FP monitor (Note 5)	System registers, devices, shared memories and errors of a Panasonic FP-series PLC connected to the COM port can be monitored. PLC password can be set or cleared.
GTWIN Ver.	Ver.3.1 or later

(Note 1): Maximum allowable number varies depending on registered contents.

(Note 2): The clock data of a connected PLC can be referred and displayed.

(Note 3): Accuracy of the GT internal clock is  $\pm 90$  seconds per month (at 25 °C). Periodically set the clock to the right time for the system in which clock error is a problem.

Note 4): It depends on the version of GT.

Note 5) Except FP7.

## 5.1.4 Interface Specifications

### ■ Interface (COM port) for connecting PLC/External devices

Item		Specifications
Communication standard		Conforms to RS-232C (Non-isolated)
Communication condition with external devices	Baud rate(bit/s)	9,600, 19,200, 38,400, 57,600, 115,200
	Data length (bit)	7, 8
	Parity	None, Odd, Even
	Stop bit (bit)	1
Transmission distance		Max. 15m (Baud rate: 19,200 bit/s)
Protocol		MEWTOCOL (Protocol for Panasonic PLC: FP series) MEWTOCOL7 (Protocol for Panasonic PLC: FP7 series) General-purpose serial (PANASONIC dedicated protocol)  Modbus RTU mode protocol (Master/Slave) Other companies' PLC protocols
Connector		D-sub 9-pin connector (Male)

### ■ Interface for transferring screen data (USB port)

Item		Specifications
Communication standard		USB2.0
Connector shape (Note 1)		USB MiniB type 5pin
Transmission distance		Max. 5 m
No. of connected units with PC		1

(Note 1): Take care of handling of the connector not to add an excessive static electricity on the metal part of the connector.

### ■ SD memory card

Item		Specifications
Support media (Note 1)		SD memory card, SDHC memory card (The manufacturer name that the operation check has done: Panasonic Corporation)
Supported format standard		Conforms to SD standard. (Please format with a format software for SD memory cards.)

(Note 1): Check the usable temperature range of a SD memory card to be used before use.

## 5.2 Dimensions

### 5.2.1 GT707 Main Unit

#### ■ Dimensions (Unit: mm)

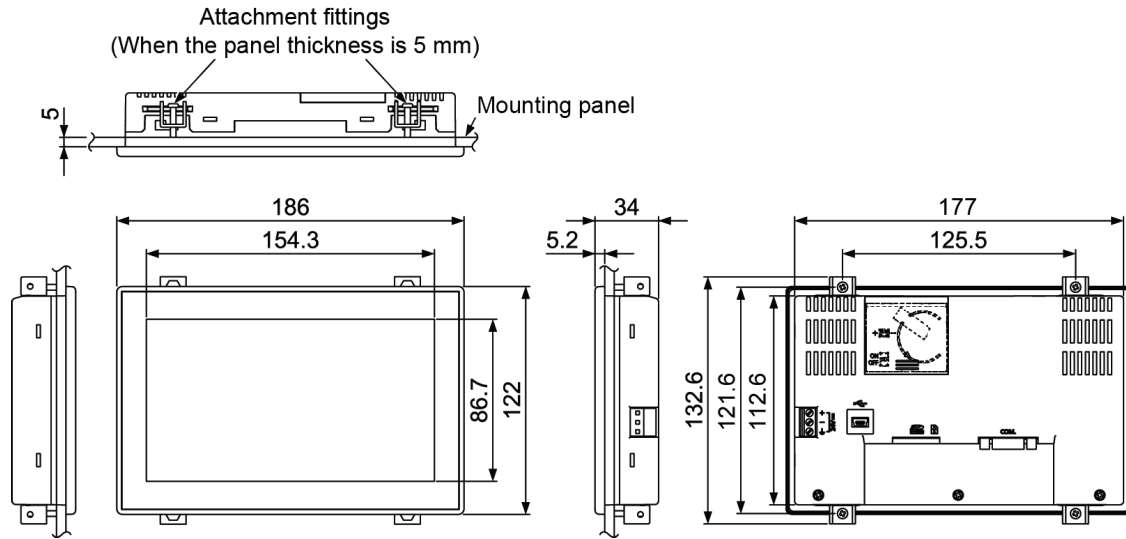

#### ■ Panel cutout dimensions (Unit: mm)





## 5.2.2 For Connecting PLC (AFC8503/AFC8503S)

This is the cable used for connecting the GT707 to the tool port of Panasonic PLC, FP0R/FP-X0.

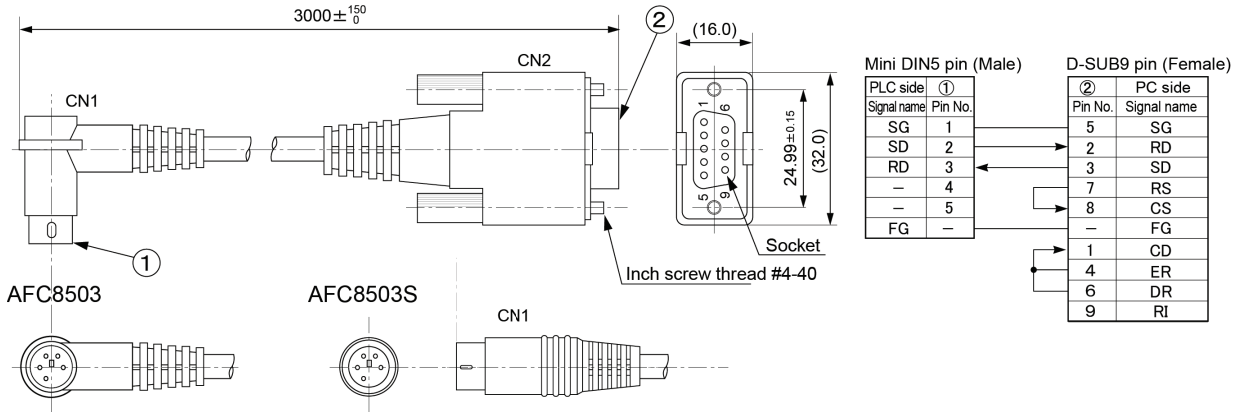



## Record of changes

Manual No.	Date	Record of Changes
WUME-GT707H-01	Aug.2015	1st Edition





Please contact .....

## Panasonic Industrial Devices SUNX Co., Ltd.

■ Overseas Sales Division (Head Office): 2431-1 Ushiyama-cho, Kasugai-shi, Aichi, 486-0901, Japan

■ Telephone: +81-568-33-7861 ■ Facsimile: +81-568-33-8591

[panasonic.net/id/pidsx/global](http://panasonic.net/id/pidsx/global)

For our sale network, please visit our website.

Aug. 2015 PRINTED IN JAPAN

© Panasonic Industrial Devices SUNX Co., Ltd. 2015  
WUME-GT707H-01

**Ramco Innovations**    [www.panasonicsensors.com](http://www.panasonicsensors.com)    **(800) 280-6933**