



* FASTUS is a product brand of OPTEX FA.

Laser Displacement Sensor CD2S Series

User's Manual

Please read this manual before using this product.

After reading it, keep this manual at hand so that it can be used whenever necessary.



Introduction



Thank you for purchasing this Laser Displacement Sensor CD2S Series.

Before using this product, please read this user's manual carefully to ensure proper use.

Read this manual thoroughly, and then keep this manual at hand so that it can be used whenever necessary.



Safety Precautions

In this manual, safety precautions for ensuring safe operation of this product are displayed as follows using the following symbols.

Precautions listed here describe important information about safety. Make sure to follow them accordingly.















■ Safety Symbols

The safety precaution symbols used and their meanings are listed below.















 Warning	Indicates that any improper operation or handling may result in moderate or minor injury, and in rare cases, serious injury or death. Also indicates a risk of serious property damage.
 Caution	Indicates that any improper operation or handling may result in minor injury or property damage.

■ Precautions

Warning

	This product cannot be used in applications that directly or indirectly detect human bodies for the purpose of ensuring safety. Do not use this product as a detection device for protecting the human body.
	Do not disassemble, repair, modify, deform under pressure, or attempt to incinerate this product. Doing so may cause injury or fire.
	This product does not have a function that stops the emission of light from the laser during disassembly. Do not disassemble the product.
	Do not use this product in water. Doing so may damage the product.
 	This product is not explosion-proof and should not be used around flammable or explosive gases or liquids. Doing so may cause ignition resulting in an explosion or fire.
 	Do not use air dusters or any spray that uses flammable gas around the product or on the inside of the product. Doing so may cause ignition resulting in an explosion or fire.
	Do not install this product in any of the following locations. Doing so may cause a fire, damage, or a malfunction. <ol style="list-style-type: none"> 1. Locations where dust, salt, iron powders, or vapor (steam) is present. 2. Locations subjected to corrosive gases or flammable gases. 3. Locations where oil or chemical splashes may occur. 4. Locations where heavy vibrations or impacts may occur. 5. Locations where the ambient temperature exceeds the rated range. 6. Locations subject to rapid temperature changes (or where condensation occurs). 7. Locations with strong electric or magnetic fields. 8. Locations subject to direct sunlight.
	This is a class A product. In a domestic environment this product may cause radio interference, in which case the user may be required to take adequate measures.
	This product is not intended for use with nuclear power, railways, aviation, vehicles, medical equipment, food-handling equipment, or any application where particular safety measures are required. Absolutely do not use this product for any of these fields.
	Do not look directly at the laser beam or intentionally shine the laser beam in another person's eyes. Doing so may have adverse effects on the eyes, including temporary blindness.
	What to do in the event of a malfunction such as smoke being emitted from the product If you detect any malfunction including emission of smoke, abnormal smells or sounds, or the body becoming very hot, immediately stop operating the product and turn off the sensor power. Failure to do so may cause a fire. Repairing the product is dangerous and should in no way be performed by the customer. Contact an OPTEX FA sales representative for repairs.
	What to do if water enters the product If water or any other liquid enters the product or the cable, immediately stop operating the product and turn off the power. Using the product in this condition may cause a fire.

Caution

	Keep wiring separate from high-voltage circuits or power circuits. If wired together, induction may be received and cause a fire, damage, or a malfunction. If wiring together is unavoidable, shield using conductive materials such as a grounded conduit.
	Do not excessively twist or apply stress to the cable. Doing so may damage the cable or connector.
	Do not drop the product or subject the product to strong impacts. Doing so may damage the product.
	The detection performance of this product may be affected if it is used in locations exposed to water or in situations where it may get wet.
	Follow the instructions in this manual or the specified instruction manual when wiring the product or the dedicated controller for the correct wiring method. Incorrect wiring can damage the product or the controller, or cause a malfunction.
	Do not bend the cable when below the freezing point. Doing so may cause the cable to break.
	Install this product as far away as possible from high-voltage equipment, power equipment, equipment that generates large switching surges, inverter motors, welders, or any equipment that can be a source of noise.
	When connecting or disconnecting the cable, make sure to hold it by the connector portion without applying excessive force to the cable.
	When removing the connector, take care not to touch the terminals inside the connector or allow any foreign objects to get inside.
	Use this product within the rated ranges.
	Install this product and dedicated controller securely. Failure to ensure secure installation may result in the product falling and becoming damaged.
	Make sure to turn the power off before wiring the cable or connecting/disconnecting the connector. Performing work while the product is energized may damage it or cause electric shock.
	Use M3 screws to mount the product and a tightening torque of 0.6 N·m or less.
	The $\varnothing 0.8$ mm hole on the side of the sensor (The side opposite the laser warning label. See the diagram on the right or “6-2. Dimension Drawings.”) is an air vent. To maintain the degree of protection, do not cover this hole or insert a sharp object into it.

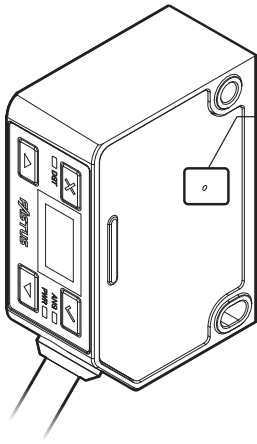

Air vent

* Do not cover the air vent with stickers or other items.

* If the sensor is mounted on a flat surface, there will be sufficient space for the offset of the mounting holes to prevent problems.

■ NOTICE

- After carefully considering the intended use, required specifications, and usage conditions, install and use the product within the specified ranges.
- All specifications may be changed without notice.
- When using this product, it is the responsibility of the customer to ensure necessary safety designs in hardware, software, and systems in order to prevent any threat to life, physical health, and property due to product malfunction or failure.
- Do not use this product for the development of weapons of mass destruction, for military use, or for any other military application. Moreover, if this product is to be exported, comply with all applicable export laws and regulations, including the “Foreign Exchange and Foreign Trade Act” and the “Export Administration Regulations,” and carry out the necessary procedures pursuant to the provisions therein.
- Before using this product, fully examine the applicable environmental laws and regulations, and operate the product in conformity to such laws and regulations. OPTEX FA does not assume any responsibility for damages or losses occurring as a result of noncompliance with applicable laws and regulations.
- If installing this product in your own equipment, ensure that the product is properly handled according to the laws and regulations of the relevant country or region.
- Detection characteristics may vary depending on individual product variations and the condition of target objects.

■ Laser Precautions

- This product emits a Class 1 visible laser beam that is compliant with IEC 60825-1 laser safety standards.
- If this product will be exported to the United States, approval must first be obtained from the FDA (Food and Drug Administration), the laser regulating body of the United States.
- A report for this product has been submitted to the CDRH (Center for Devices and Radiological Health).
- Performing control or calibration in manners other than those specified herein may result in exposure to hazardous laser radiation.

Laser label



Symbol	Meaning
	Laser emission
LASER 1	Class 1 laser product

Laser warning label position

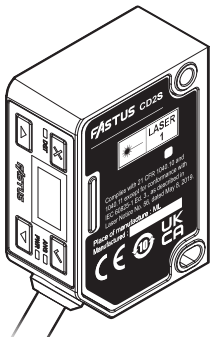

Type of laser used in this product

Type	Red semiconductor laser
Wavelength	655 nm
Maximum output	0.39 mW

Expressions Used in This Manual

This section explains the expressions used in this manual.

Caution

Indicates an item that requires special attention during use.

MEMO

Indicates information that is useful to know during use.

■ Included display images

Note that display images included in this user's manual are subject to change without prior notice due to product improvements.

Manual Structure

1

2

3

4

5

6

7

This manual consists of the following contents.

1. Read Before Use	This chapter explains included items and part names.
2. Installation and Connection	This chapter explains how to install and wire this product.
3. Screen Displays and Operation	This chapter explains the screen displays of this product and their operation.
4. Menu List	This chapter shows a menu list and a list of the setting items that can be set with this product.
5. IO-Link	This chapter introduces how to use the product as an IO-Link device.
6. Specifications	This chapter describes the specifications, dimension drawings, and other characteristics of this product.
7. Troubleshooting	This chapter describes how to maintain this product.

1-1 Contents

.....

Introduction.....	i
Safety Precautions	ii
Expressions Used in This Manual	vi
Manual Structure	vii

1 Read Before Use

1-1	Included Items	1-2
1-1-1	Options	1-2
1-2	Part Names	1-3

2 Installation and Connection

2-1	Mounting the Sensor	2-2
2-2	I/O Circuit Diagrams	2-5

3 Screen Displays and Operation

3-1	Screen Display	3-2
3-1-1	Measurement screen	3-2
3-1-2	Main Menu display	3-4
3-1-3	Settings Screen	3-5
3-2	When turning on power for the first time	3-7
3-3	Key Lock Function	3-8
3-3-1	Screen Operation	3-8

4 Menu List

4-1	Setting Mode Menu	4-2
4-2	[A] Measurement setting	4-4
4-2-1	[A1] Sampling Period	4-4
4-2-2	[A2] Moving Average	4-4
4-2-3	[A3] Median Filter	4-4
4-2-4	[A4] Measurement Direction	4-5
4-2-5	[A5] Measured Value Offset	4-6
4-2-6	[A6] Mask Near, [A7] Mask Far	4-7
4-2-7	[A8] Error Mode	4-8
4-2-8	[A9] Set Clamp Value	4-9
4-2-9	[A10] Error Hold Time	4-9
4-2-10	[A11] Span Teach	4-9
4-2-11	[A12] Peak Select	4-10
4-2-12	[A13] Peak Selection Threshold	4-10
4-3	[B] Output 1 (Output 2)	4-11
4-3-1	[B1] Mode	4-11
4-3-2	[B2] Teach 1 Auto	4-14
4-3-3	[B3] Threshold1	4-14
4-3-4	[B4] Teach 2 Auto	4-14
4-3-5	[B5] Threshold2	4-14
4-3-6	[B6] Output Mode	4-15
4-3-7	[B7] Delay Timer	4-16
4-3-8	[B8] Timer Set	4-17
4-3-9	[B9] Hysteresis	4-18
4-3-10	[B10] Tolerance	4-19
4-4	[C] Analog	4-20
4-4-1	[C1] Analog Output	4-20
4-4-2	[C2] 4 mA Teach	4-21
4-4-3	[C3] 4 mA Manual/[C5] 20 mA Manual	4-21
4-4-4	[C4] 20 mA Teach	4-21

4-4-5	[C6] 0 V Teach	4-21
4-4-6	[C7] 0 V Manual/[C9] 10 V Manual	4-21
4-4-7	[C8] 10 V Teach	4-21
4-5	[D] Input	4-22
4-5-1	[D1] Input Function	4-22
4-5-2	[D2] Input Hold Mode	4-24
4-5-3	[D3] Input Delay	4-25
4-5-4	[D4] Input Mode	4-25
4-6	[E] Device	4-26
4-6-1	[E1] Reset Factory Settings	4-26
4-6-2	[E2] Save Customer Settings	4-26
4-6-3	[E3] Apply Customer Settings	4-26
4-6-4	[E4] Reset Calibration	4-26
4-6-5	[E5] Language	4-27
4-6-6	[E6] Display Off Time	4-27
4-6-7	[E7] Display Brightness	4-27
4-6-8	[E8] Rotate Display	4-27
4-6-9	[E9] Laser	4-28
4-6-10	[E10] Output Polarity	4-28
4-6-11	[E11] No of Decimal Places	4-28
4-7	[G] Information	4-29
4-7-1	[G1] Model Number	4-29
4-7-2	[G2] Serial Number	4-29
4-7-3	[G3] Firmware Version	4-29
4-7-4	[G4] Sensor Operating Hours	4-29
4-7-5	[G5] Laser Operating Hours	4-29
4-7-6	[G6] Internal Temperature	4-29
4-7-7	[G7] Error Counter	4-30
4-7-8	[G8] Error History	4-31
4-8	Quick Set Menu	4-32

5 IO-Link

5-1	Index list	5-2
5-1-1	Communication Specifications	5-2
5-1-2	Process data format	5-3
5-1-3	Service Data	5-5
5-2	Events and Errors	5-13
5-2-1	Events	5-13
5-2-2	Error function	5-13
5-3	IO-Link Master UR Series Connection Settings	5-14
5-3-1	Functions When Connecting the CD2S and the UR	5-14

6 Specifications

6-1	Specifications	6-2
6-1-1	Measurement specifications	6-2
6-1-2	Common Specifications	6-2
6-2	Dimension Drawings	6-4
6-3	Characteristics	6-6
6-3-1	Spot Size	6-6
6-3-2	Interference Area	6-8
6-3-3	Light Axis Area	6-10

7 Troubleshooting

7-1	When an error occurs	7-2
7-1-1	Warning indicators shown when an error occurs	7-2
7-1-2	Error Causes and Troubleshooting	7-2
7-2	What should I do in this situation?	7-4



Read Before Use

This chapter explains included items and part names.

1-1 Included Items

Before using this product, confirm that all included items are present.

If the product is defective or damaged, please contact OPTEX FA (contact info provided at end of manual).

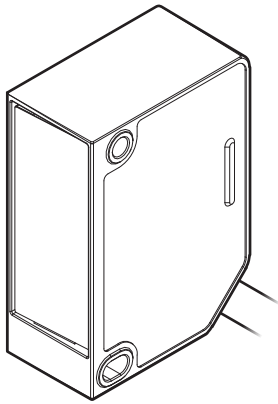

Sensor

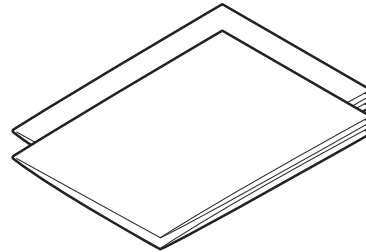

INSTRUCTION MANUAL: Japanese 1 copy, English 1 copy

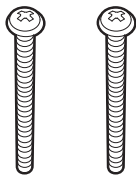

M3×25 mm mounting screws × 2

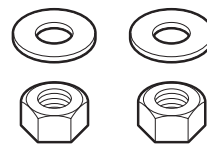

Washers, M3 nuts × 2 sets

1-1-1 Options

Model	Cable length	Minimum bending radius	Remarks
YF2A15-020VB5XLEAX	2 m	26 mm (when fixed in place)	
YF2A15-050VB5XLEAX	5 m	26 mm (when fixed in place)	
YF2A15-100VB5XLEAX	10 m	26 mm (when fixed in place)	
DOL-1205-G02M-R	2 m	9 mm (when fixed in place) 27 mm (when movable)	Bend-resistant cable
DOL-1205-G05M-R	5 m	9 mm (when fixed in place) 27 mm (when movable)	Bend-resistant cable

See “6-2 Dimension Drawings” for more information on dimension drawings.

1-2 Part Names

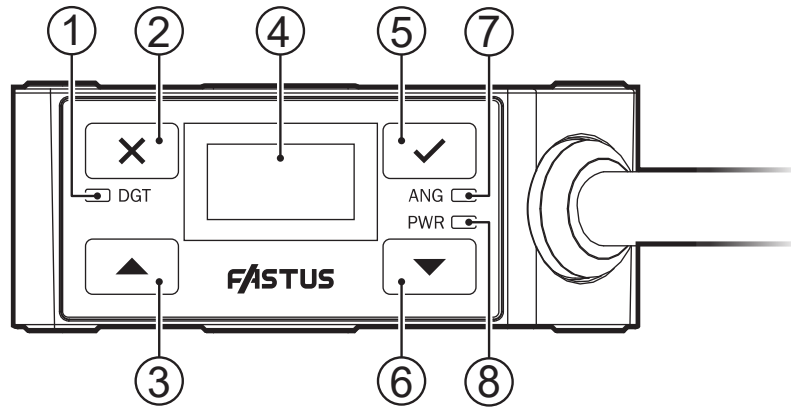

No.	Name	Status
①	Output indicator	Lits orange when control output is on and blinks red in the event of an error.
②	Cancel key (×)	Short press: Cancels the menu item. Long press: Changes the measurement value display from Measurement value (relative) to Measurement value (absolute).
③	Selection key (△)	Move setting menus or increase values when entering items.
④	Display	Shows measurement values and setting menus.
⑤	Enter key (✓)	Short press: Move to setting screen, determine menu item, and enter setting range. Long press: Move to set screen, from measurement value display.
⑥	Selection key (▽)	Move the setting menus or decrease values when entering items.
⑦	Analog output indicator	Lits orange when analog signal is output. Blinks red when laser is off.
⑧	Power indicator	Lits green when power is on and blinks green during IO-Link communication.



2

Installation and Connection

This chapter explains how to install and wire this product.

2-1 Mounting the Sensor

Note

Take care to observe the following when handling the sensor head cable. Excessive stress on the cable may lead to breakage.

- Do not pull on the cable with a force of 30 N or more.
- The minimum bending radius should be at least twice the diameter of the cable when fixed in place or at least six times the cable diameter when movable.
- Make sure there is at least 30 mm between the sensor head and any bend in the cable.
- Tighten the sensor head mounting screws (included screws or the like) with a tightening torque of no more than 0.8 N·m.

Excessive tightening torque may damage the sensor head.

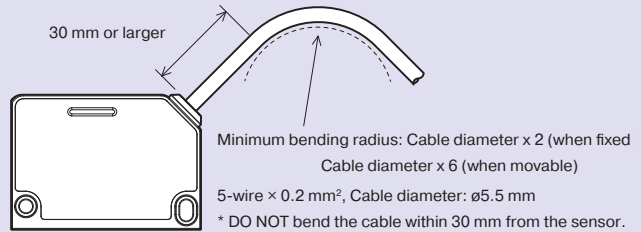

■ Mounting

Mount the sensor head to a wall or bracket using the included screws (or equivalent screws).

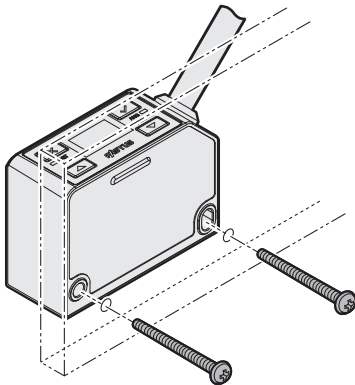

■ Notes on installation

Adjust the laser beam so that it irradiates the measured object as close to perpendicular as possible.

- Diffuse reflection setting

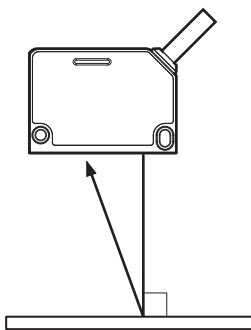

To ensure high detection accuracy and stability, mount the sensor as shown for the applicable target.

● With height differences

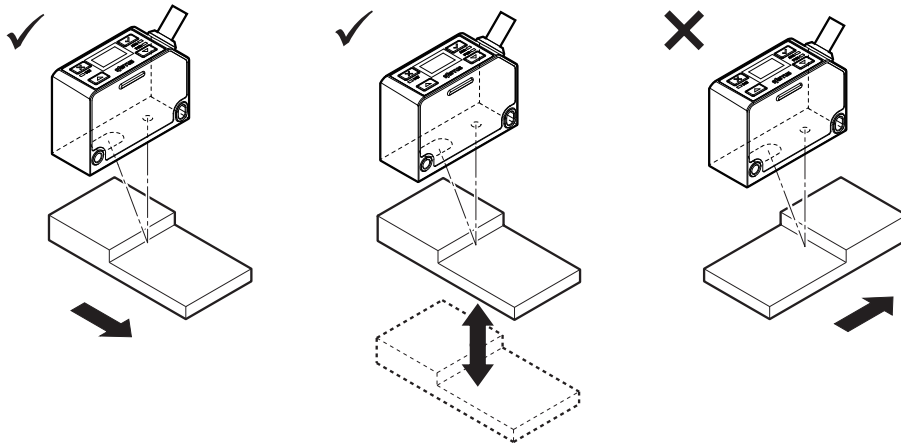

● With material/color differences

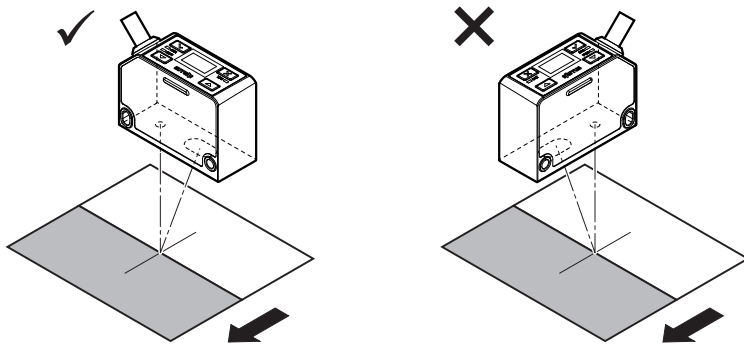

● With rotating measurement targets

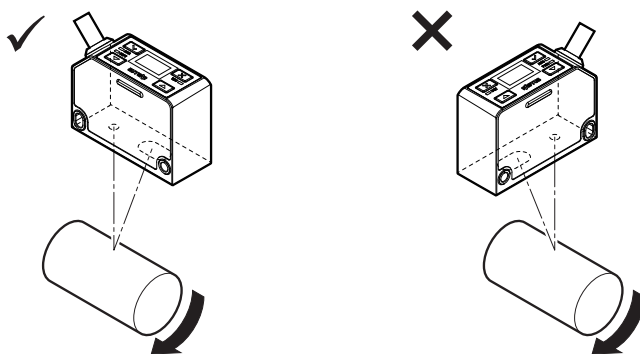

● With holes or recesses

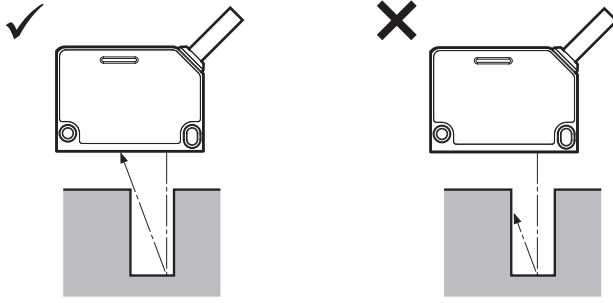

● When mounted on a wall

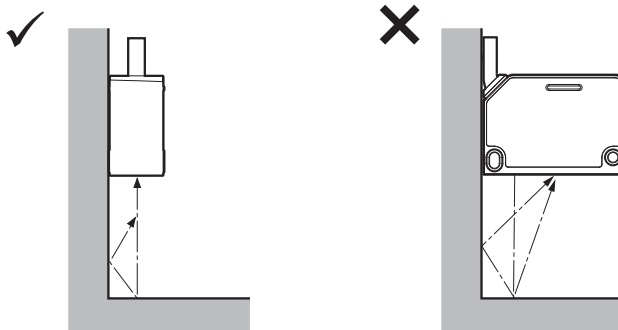

Attach the sensor head so that the detection side (emitting/receiving surfaces) is parallel to the detection target.

Adjust the installation so that the spot aligns with the detection position, and check whether the analog output indicator (orange) lights up.

(default setting)

Note

■ Warmup

Wait approximately 10 minutes after turning on the power before use. Measurements performed directly after turning on the power will gradually drift (change) over time.

■ Effects of dirt and dust

Measurement errors may occur due to dirt or dust as well as water or oil.

- If the glass cover or the surface of the measured object becomes dirty, remove the dirt by blowing it off with clean air.
- If the glass cover becomes excessively dirty, wipe it with a soft cloth.

2-2 I/O Circuit Diagrams

NPN setting*1

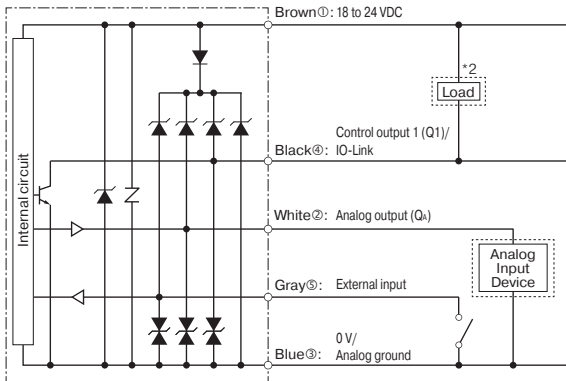

PNP setting

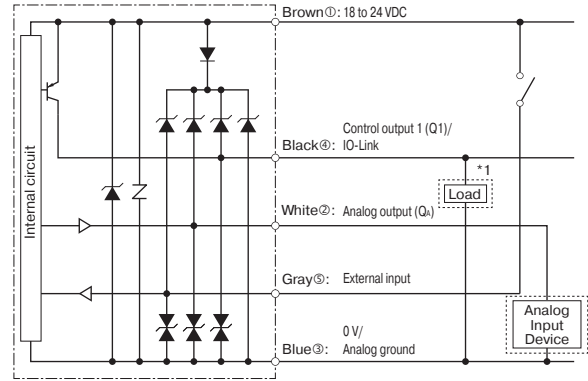

*1: When connecting to IO-Link with the NPN setting, use the IO-Link Master UR Series or a sink-type compatible IO-Link Master.

*2: When used as control output 1 (Q1)

*1: When used as control output 1 (Q1)

Push-pull setting

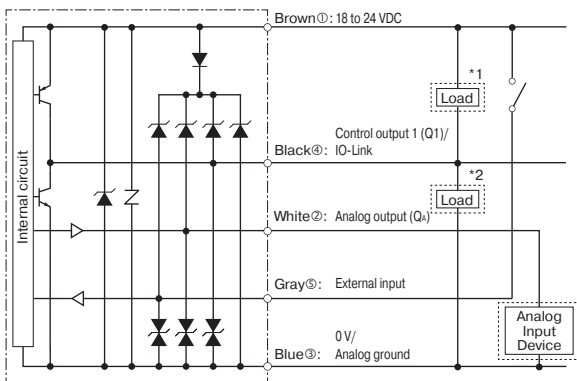

*1: When used as control output 1 (Q1) with NPN connection

*2: When used as control output 1 (Q1) with PNP connection

M12 connector pin assignments

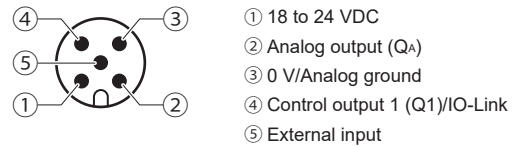



3

Screen Displays and Operation

This chapter explains the screen displays of this product and their operation.

3-1 Screen Display

There are the following two types of screen displays.

Screen display	Description
Measurement screen	Displays measured values (relative, absolute), analog output values, and received light waveforms.
Settings screen	Used to change settings in the various settings menus.

Measurement screen



Settings screen



3-1-1 Measurement screen



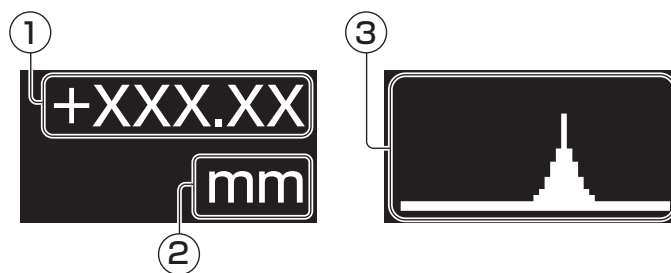

■ Displays



No.	Displayed item	Description
①	Measured value	Displays current measured values when Distance (rel.) or Distance (abs.) is selected.
	Analog output	Displays current or voltage values when analog output is selected.
②	Unit	Displays Distance (rel.) and Distance (abs.) in millimeters (mm). During analog output, current output is displayed in mA and voltage output is displayed in V.
③	Received light waveform	Displays the received light waveforms within the measurement range.

■ Screen Operation

The following operations can be performed on the Measurement screen.

Operation key	Key operation	Description
	Short press	Cancels item settings made on the Quick Set screen.
	Long press	Switches from Distance (rel.) to Distance (abs.).
	Short press	Confirms item settings made on the Quick Set screen.
	Long press	Moves from the Measurement screen to the Quick Set screen.
	Short press	Changes items displayed on the Measurement screen. Increases the values of items input on the Quick Set screen.
	Short press	Changes items displayed on the Measurement screen. Decreases the values of items input on the Quick Set screen.

■ Screen Transitions

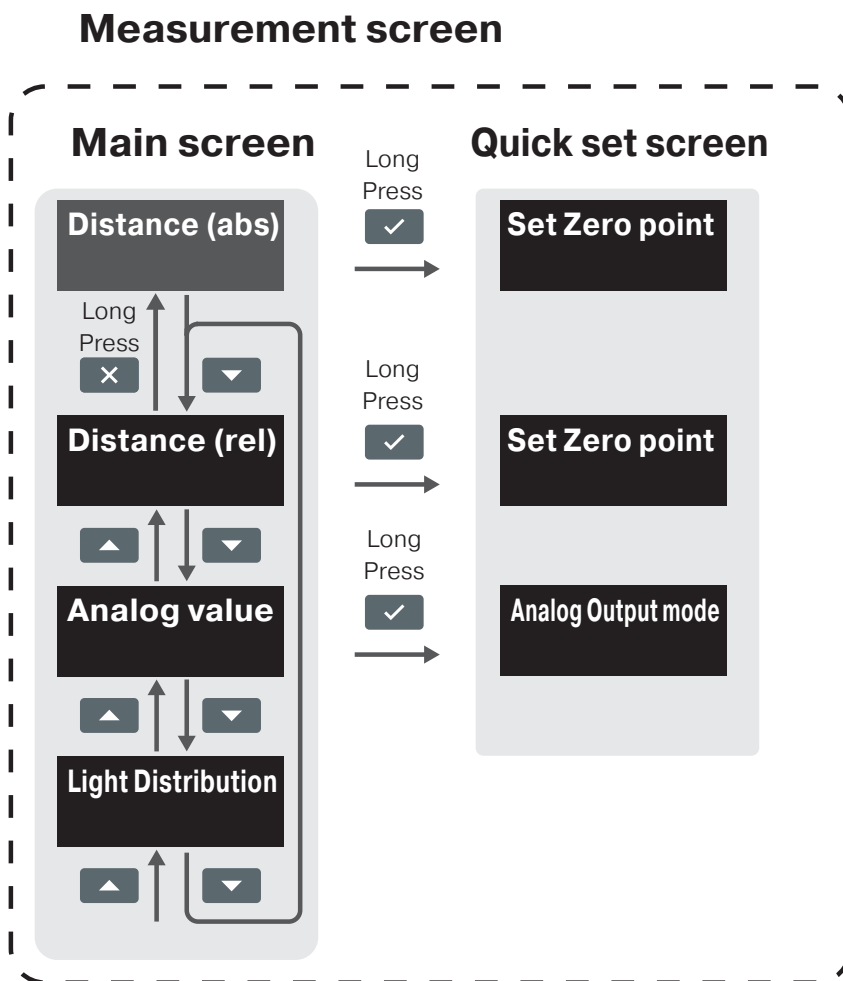

* See “4-8 Quick Set Menu” on page 4-32 for details on setting items from the Quick Set screen.

3-1-2 Main Menu display

■ Measured Value Display

This product has two types of Measurement screen displays: “Distance (rel.)” and “Distance (abs.)”

● Distance (rel.)

Displays 0 mm at the center of the measurement range. Thresholds are set and displayed as relative values. If an offset value is set, it will be applied to the measured value (relative).

(See  “4-2-5 [A5] Measured Value Offset” (page 4-6) for how to set offset values.)

●●● MEMO ●●●

- Setting an offset value causes the display color to be inverted when the measured value (relative) is displayed.
Operation example: When offset value is set to -10



● Measured Value (abs.)

Displayed as the distance from the end face of the sensor head.

Even if an offset value is set, it will not be applied.

Example: Measured value displays (absolute and relative) for the CD2S-110

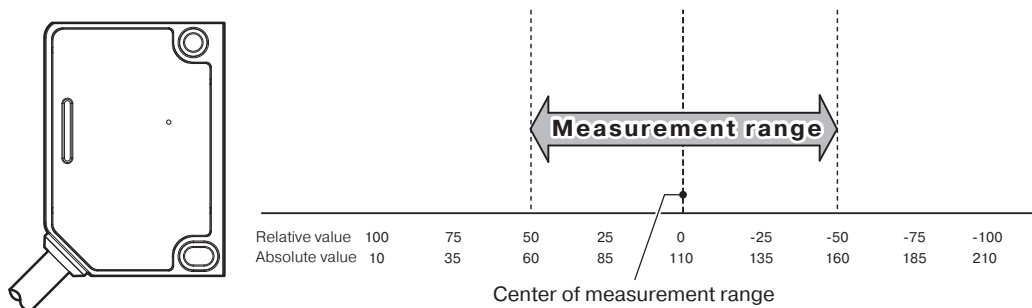

■ Analog Output Display

Displays current analog output values (current/voltage).

- Press and hold to select the analog output (4...20 mA, 0...10 V, OFF).

●●● MEMO ●●●

“0.0 V” is displayed if analog output is set to “OFF.”

■ Received Light Waveform Display

Displays received light within the measurement range as waveforms.

If received light waveforms are small, make them larger by setting a longer sampling period or changing the setting to AUTO.

3-1-3 Settings Screen

■ Displays

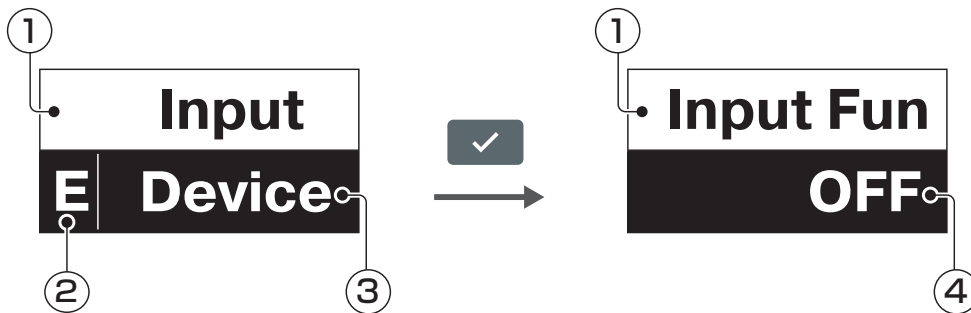

No.	Displayed item	Description
①	Selected setting item	The selected setting item is displayed with its colors inverted.
②	Setting item code	Codes are assigned to each setting item. Main menu: A to G Sub menu: Main menu code + number
③	Setting item	Displays the next setting item.
④	Setting value	Displays the value set for the setting item.

■ Screen Operation

Operation key	Key operation	Description
	Short press	Cancels item settings. Returns to the Main menu from the Sub menu.
	Short press	Confirms item settings. Moves from the Main menu to the Sub menu.
	Short press	Changes items displayed on the Setting screen. Increases the values of items input in item settings.
	Short press	Changes items displayed on the Setting screen. Decreases the values of items input in item settings.

■ Screen Transitions

Settings screen

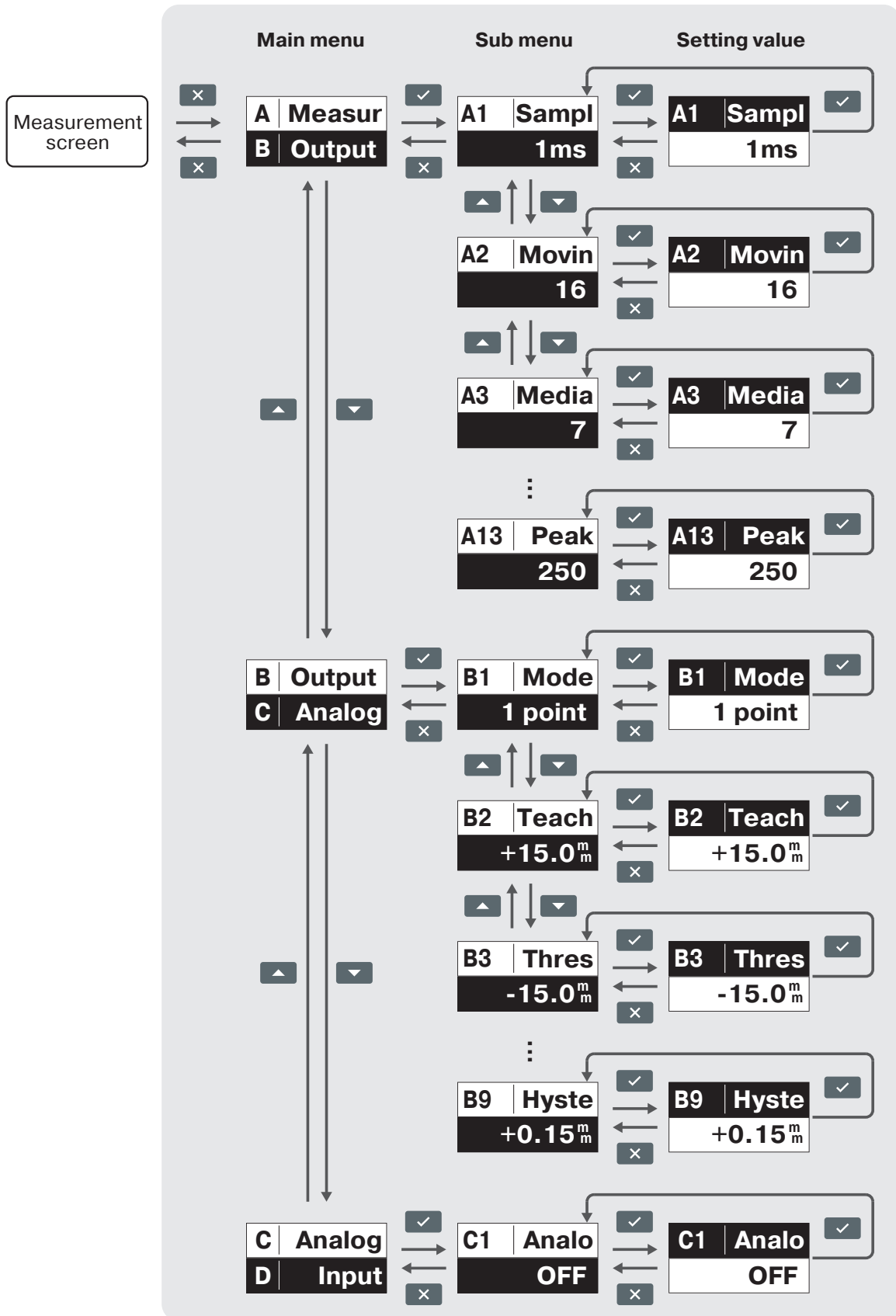

(See “Menu List” on page 4-1 for details on item settings.)

3-2 When turning on power for the first time

The initial setup screen will be displayed when turning on power for the first time. Please perform initial setup using the following procedure.

The information provided in this user's manual is based on the display language being set to "English."

MEMO

The initial setup screen will only be displayed when turning on power for the first time and will not be shown thereafter.

See  "4-6-1 [E1] Reset Factory Settings" (page 4-26) for information on performing initial setup.

1 The initial setup screen is displayed.





Language
Japanese

2 Sets the display language.

Press the  key.

The cursor position moves from "[I1] Language" to "Japanese."

Press the  or  key to select the display language (Japanese/Traditional Chinese/Korean/English/German/Spanish/Simplified Chinese), and then press the  key.





I1 | Language
Japanese

3 Select the output type.

Press the  key.

The cursor position moves from "[I2] Output Polarity" to "NPN."

Press the  or  key to select the output type (NPN/PP/PNP), and then press the  key.





I2 | Output
NPN

4 Select Analog Output.

Press the  key.

The cursor position moves from "[I3] Analog Output" to "4...20 mA."

Press the  or  key to select the output type (4...20 mA/0...10 V/OFF), and then press the  key.



I3 | Analog
4...20 mA

5 Return to the Measurement screen.

3-3 Key Lock Function

Malfuctions can be prevented by prohibiting changes to settings.

3-3-1 Screen Operation

■ Enabling the Key Lock

1 On the Measurement screen, press and hold +.



2 The display will then show the lock icon and the text "Locked" and the keys will be locked.



3 The lock icon and "Locked" will be displayed for 3 seconds, then the display returns to the Measurement screen.



■ Disabling the Key Lock

1 On the Measurement screen, press and hold +.



2 The display will then show the lock icon and the text "Unlocked" and the keys will be unlocked.



3 The lock icon and "Unlocked" will be displayed for 3 seconds, then the display returns to the Measurement screen.





4

Menu List

This chapter shows a menu list and a list of the setting items that can be set with this product.

4-1 Setting Mode Menu

When “English” is selected using “[E5] Language.”

Main menu		Sub menu		Setting value/ Description	Default value	Reference page
A	Measurement	A1	Sampling period	333 μ s/500 μ s/1 ms/2 ms/4 ms/8 ms/16 ms/Auto	1 ms	page 4-4
		A2	Moving Average	OFF/4/16/64/128	16	page 4-4
		A3	Median Filter	OFF/3/7/15	7	page 4-4
		A4	Measurement Direction	Positive/Negative	Negative	page 4-5
		A5	Measured Value Offset	-400.000 to +400.000 mm	0 mm	page 4-6
		A6	Mask Near	CD2S-30x: -5.5 to +5.5 mm CD2S-50x: -16.5 to +16.5 mm CD2S-110x: -53.0 to +53.0 mm	-5.5 mm -16.5 mm -53.0 mm	page 4-7
		A7	Mask Far	CD2S-30x: -5.5 to +5.5 mm CD2S-50x: -16.5 to +16.5 mm CD2S-110x: -53.0 to +53.0 mm	+5.5 mm +16.5 mm +53.0 mm	page 4-7
		A8	Error Mode	Clamp value/Hold Last Value/Hold Last Value+timer	Clamp value	page 4-8
		A9	Set Clamp Value	-999.999 to +999.999 mm	+999.999 mm	page 4-9
		A10	Error Hold Time	1 to 9999 ms	100 ms	page 4-9
		A11	Span Teach	The Span Teach(Auto) is calculated using the measurement value by teach for two points and the adjusted measurement value entered by the user. Setting range: -2.0 to +2.0		page 4-9
		A12	Peak Select	OFF/Near Side/Far Side	OFF	page 4-10
		A13	Peak Selection Threshold	0 to 4095	250	page 4-10
B	Output 1 Digital Output 2	B1	Mode	1 point/Window/FGS 1-point/Light level error/2 point/OFF	1 point	page 4-11
		B2	Teach 1 Auto	Save the current value as SP1		page 4-14
		B3	Threshold1	-524.287 to +524.287 mm	CD2S-30x: -5.00 mm CD2S-50x: -15.00 mm CD2S-110x: -50.0 mm Light level error: 2048	page 4-14
		B4	Teach 2 Auto	Save the current value as SP2		page 4-14
		B5	Threshold2	-524.287 to +524.287 mm	CD2S-30x: +5.00 mm CD2S-50x: +15.00 mm CD2S-110x: +50.0 mm	page 4-14
		B6	Output Mode	N.O./N.C.	N.O.	page 4-15
		B7	Delay Timer	OFF/On Delay/Off Delay/On/off Delay/One Shot	OFF	page 4-16
		B8	Timer Set	1 to 10000 ms	100	page 4-17
		B9	Hysteresis	0 to +524.287 mm	CD2S-30x: +0.05 mm CD2S-50x: +0.15 mm CD2S-110x: +0.5 mm	page 4-18
		B10	Tolerance	0 to 524.287 mm	CD2S-30x: 0.20 mm CD2S-50x: 0.60 mm CD2S-110x: 2.0 mm	page 4-19
C	Analog	C1	Analog Output	4...20 mA/0...10 V/OFF	4...20 mA	page 4-20
		C2	4 mA Teach	Teach and save current measurement value as 4 mA		page 4-21
		C3	4 mA Manual	-524.287 to +524.287 mm	CD2S-30x: -5.00 mm CD2S-50x: -15.00 mm CD2S-110x: -50.0 mm	page 4-21
		C4	20 mA Teach	Teach and save current measurement value as 20 mA		page 4-21

Main menu		Sub menu		Setting value/ Description	Default value	Reference page
C	Analog	C5	20 mA Manual	-524.287 to +524.287 mm	CD2S-30x: +5.00 mm CD2S-50x: +15.00 mm CD2S-110x: +50.0 mm	page 4-21
		C6	0 V Teach	Teach and save current measurement value as 0 V		page 4-21
		C7	0 V Manual	-524.287 to +524.287 mm	CD2S-30x: -5.00 mm CD2S-50x: -15.00 mm CD2S-110x: -50.0 mm	page 4-21
		C8	10 V Teach	Teach and save current measurement value as 10 V		page 4-21
		C9	10 V Manual	-524.287 to +524.287 mm	CD2S-30x: +5.00 mm CD2S-50x: +15.00 mm CD2S-110x: +50.0 mm	page 4-21
D	Input	D1	Input Function	OFF/Threshold Teach/Analog Teach/Hold/ Zero Point Teach-in/Laser Off	OFF	page 4-22
		D2	Input Hold Mode	Measured Value/Peak Value/Lowest Value	Measured Value	page 4-24
		D3	Input Delay	No/Yes	No	page 4-25
		D4	Input Mode	N.O./N.C.	N.O.	page 4-25
E	Device	E1	Reset Factory Settings	No/Yes	-	page 4-26
		E2	Save Customer Settings	No/Yes	-	page 4-26
		E3	Apply Customer Settings	Yes/No	-	page 4-26
		E4	Reset Calibration	Yes/No	-	page 4-26
		E5	Language	English/German/Spanish/Simplified Chinese/ Japanese/Traditional Chinese/Korean	Japanese	page 4-27
		E6	Display Off Time	OFF/10/20/60/300/1200/3600 sec	300 sec	page 4-27
		E7	Display Brightness	0/10/20/30/40/50/60/70/80/90/100 %	30%	page 4-27
		E8	Rotate Display	0°/180°	0°	page 4-27
		E9	Laser	ON/OFF	ON	page 4-28
		E10	Output Polarity	PNP/NPN/PP	NPN	page 4-28
		E11	No of Decimal Places	0/0.1/0.01/0.001	CD2S-30x: 0.01 CD2S-50x: 0.01 CD2S-110x: 0.1	page 4-28
G	Information	G1	Model Number	Product No.	-	page 4-29
		G2	Serial Number	Displays the production period of the product.	-	page 4-29
		G3	Firmware Version	Displays the software version of the product.	-	page 4-29
		G4	Sensor Operating Hours	Total time with sensor powered on (Hours: Minutes)	-	page 4-29
		G5	Laser operating hours	Total time of laser emission (Hours: Minutes)	-	page 4-29
		G6	Internal Temperature	Sensor internal temperature (°C).	-	page 4-29
		G7	Error Counter	The number of errors is counted up to 256 times, stored and displayed for each type of error.	-	page 4-30
		G8	Error History	Up to 10 errors are stored and displayed. If an 11th error occurs, it is overwritten from the oldest error.	-	page 4-31

4-2 [A] Measurement setting

4-2-1 [A1] Sampling Period

Sets the time needed to perform one measurement (sampling time).

When using a fast setting, the response time becomes fast, but the received light amount is reduced. This may prevent measurement from being possible at long distances, for black targets with minimal reflection, or for tilted targets.

When using a slow setting, the response time becomes slow, and the received light amount is increased.

Item	Setting value	Default value
Sampling Period	333 μ s/500 μ s/1 ms/2 ms/4 ms/8 ms/16 ms/Auto	1 ms

* When set to Auto, the sampling period is automatically adjusted beyond the fixed sampling range to obtain the optimum amount of reflected light and ensure the fastest possible sampling received light intensity.

4-2-2 [A2] Moving Average

Performs averaging for the measured values.

If measured values fluctuate, increasing the number of averages will provide more stable measurement results, but processing the measured values takes longer.

Item	Setting value	Default value
Moving Average	OFF/4/16/64/128	16

4-2-3 [A3] Median Filter

Cuts off sudden changes in measured values to help reduce variations. The median value of the measured values within the set measurement count is used as the definite value.

Using this in combination with the moving average should help stabilize measurement.

Item	Setting value	Default value
Median Filter	OFF/3/7/15	7

4-2-4 [A4] Measurement Direction

Sets whether to increase or decrease the height of the measured value with 0 mm as the center of the measurement range.

This setting applies to measured values (relative) and threshold settings.

Item	Setting value	Default value
Measurement Direction	Positive/Negative	Negative

Negative

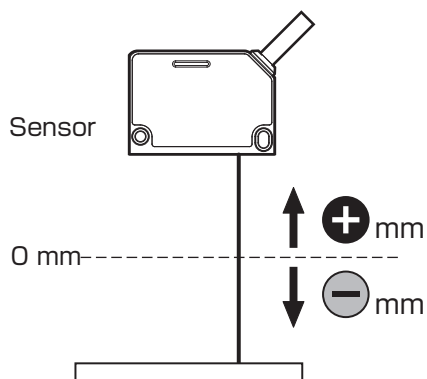

Measured values will increase as the object moves closer to the sensor head.

Positive

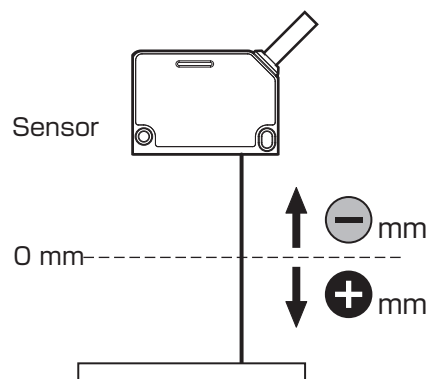

Measured values will increase as the object moves farther from the sensor head.

4-2-5 [A5] Measured Value Offset

Stores the offset amount so that the measured value (relative) becomes zero during offset operation.

Resetting the offset will return the offset value to 0 (zero).

The offset value will be updated during each offset operation.

Enter offset values manually as desired.

Item	Setting value	Default value
Measured Value Offset	-400.000 to +400.000 mm	0 mm

* The measured value (relative) becomes 0 (zero) at the center of measurement range for each sensor by default (110 mm for the CD2S-110).

* The analog output range is also offset during offset operation.

The position at which offset is performed becomes the analog output center value.

- When 4 to 20 mA is selected, the offset position becomes 12 mA.
- When 0 to 10 V is selected, the offset position becomes 5 V.

Example: If the CD2S-110 indicates a measured value (relative) of 25.0 mm and offset adjustment is performed, 25.0 mm will be stored as the analog output and [A5] measured value offset.

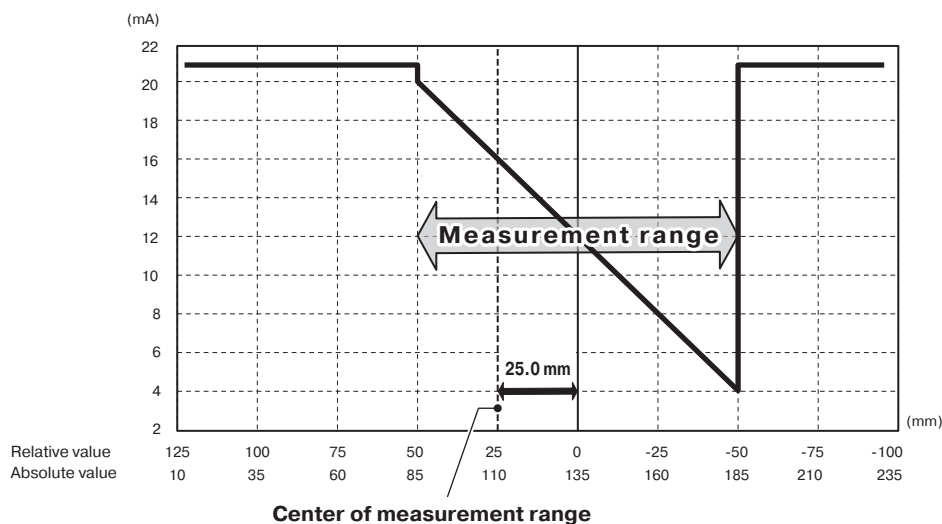

MEMO

Setting an offset value will cause the display color to be inverted when the measured value (relative) is displayed.

- Operation example: When offset value is set to -10



4-2-6 [A6] Mask Near, [A7] Mask Far

Sets a masked range where measurement will not be performed within the measurement range.

This setting can be used to ignore surrounding ambient light or measured objects that are not measurement targets.

It is recommended to use the received light waveform mode when using this setting.

■ Mask Near

For near-side measurements, the mask will be applied between the near-side measurement limit and the setting value.

Item	Setting value	Default value
Mask Near	CD2S-30x: -5.5 to +5.5mm	-5.50 mm
	CD2S-50x: -16.5 to +16.5mm	-16.50 mm
	CD2S-110x: -53.0 to +53.0mm	-53.0 mm

■ Mask Far

For far-side measurements, the mask will be applied between the far-side measurement limit and the setting value.

Item	Setting value	Default value
Mask Far	CD2S-30x: -5.5 to +5.5mm	+5.50 mm
	CD2S-50x: -16.5 to +16.5mm	+16.50 mm
	CD2S-110x: -53.0 to +53.0mm	+53.0 mm

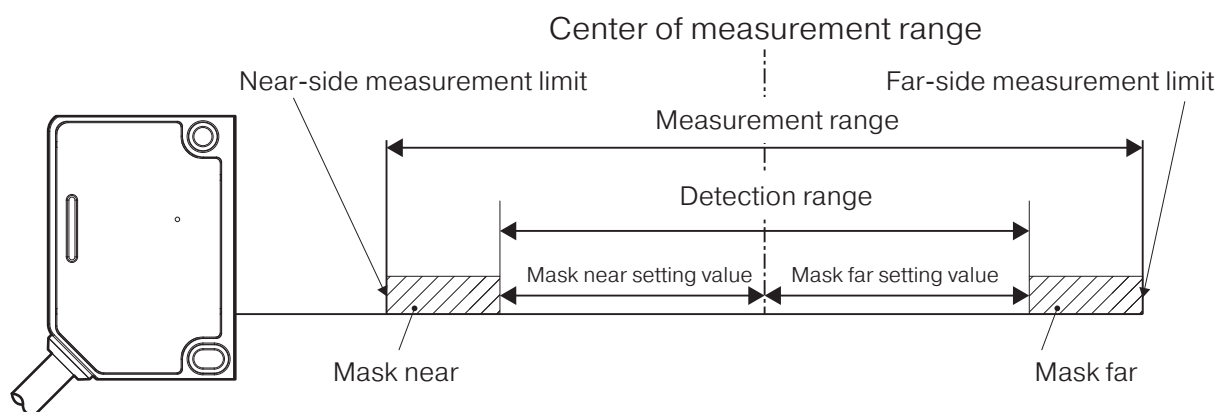

MEMO

The mask setting value is set to a wider range than the set value.

Because the default value is set outside the near-side and far-side measurement limits, no mask is applied with the default value.

4-2-7 [A8] Error Mode

Sets the behavior when an alarm occurs (when measurement is not impossible due to being outside the measurement range or insufficient light).

Item	Setting value	Default value
Error Mode	Clamp Value/Hold Last Value/Hold Last Value+timer	Clamp Value

● Clamp Value

While the alarm is detected, the measured value becomes the set clamp value and the clamp is released once measurement becomes possible again.

See “4-2-8 [A9] Set Clamp Value” on page 4-9 for setting the set clamp value.

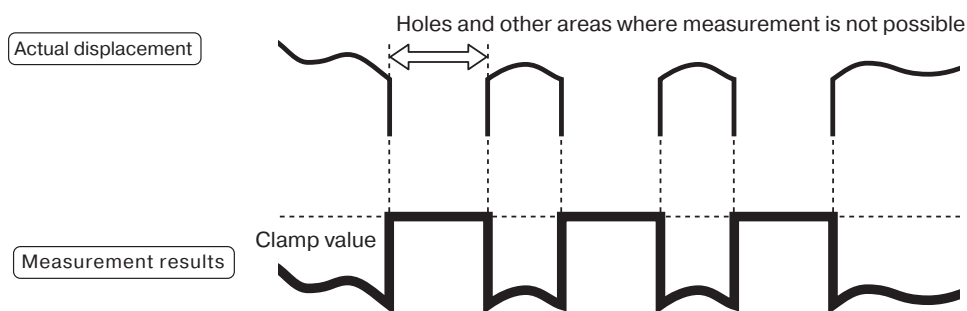

● Hold Last Value

While the alarm is detected, the previously measured value is held and is released once measurement becomes possible again.

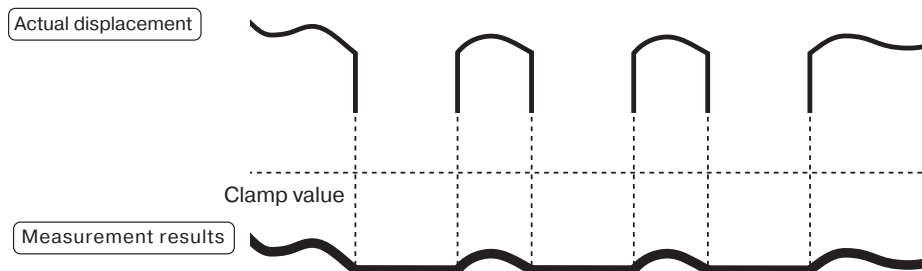

● Hold Last Value + timer

Performs a “Clamp value” operation after the “Hold last value” operation is performed for the specified time.

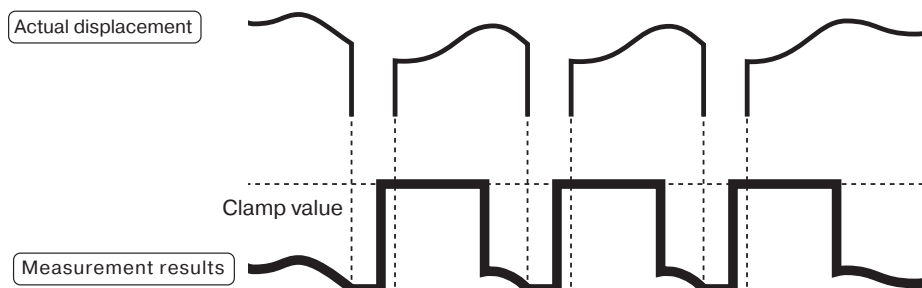

4-2-8 [A9] Set Clamp Value

Sets the value to be displayed when an alarm occurs (when outside the measurement range or when measurement is not possible).

The measured value specified here will be displayed when “Clamp value” is selected using [A8] Error Mode.

Item	Setting value	Default value
Set Clamp Value	-999.999 mm to +999.999 mm	+999.999 mm

4-2-9 [A10] Error Hold Time

The length of time the value immediately before the alarm occurred is held can be set in units of 1 ms.

The hold time specified here will be displayed when “Hold last value + timer” is selected using [A8] Error Mode.

Item	Setting value	Default value
Error Hold Time	1 ms to 9999 ms	100 ms

4-2-10 [A11] Span Teach

The Span Teach (Auto) is calculated using the measurement value by teach for two points and the adjusted measurement value entered by the user.

Item	Setting value	Default value
Span Teach	-2.0 to +2.0	-

● Setup Procedure

- 1 Set the reference point by performing Set zero point with no measured object.

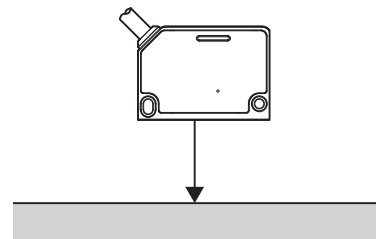

- 2 Place the measured object and teach the measured value before calibration.

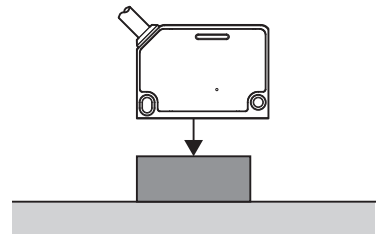

- 3 Enter the adjusted measurement value.
The span value is calculated once entered.

4-2-11 [A12] Peak Select

When multiple peaks are detected, you can select whether to use near- or far-side peak for measurement. If "OFF" is selected, the peak with the highest light level is selected.

Item	Setting value	Default value
Peak Select	OFF/Near Side/Far Side	OFF

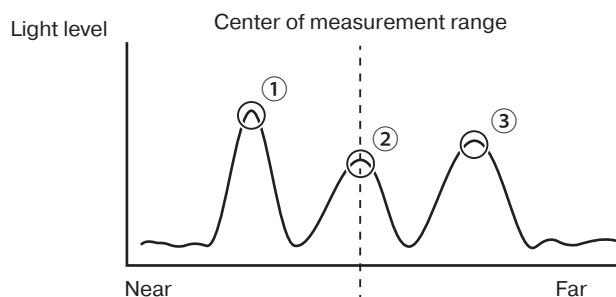

If near side is selected, the selected peak will be ①.

If far side is selected, the selected peak will be ③.

If OFF is selected, it will be ①.

Caution

If [A13] Peak Selection Threshold is set too high, the peak waveform will not be recognized and peak selection will not be possible.

4-2-12 [A13] Peak Selection Threshold

This is the light level threshold when measuring the peak selected using [A12] Peak Select.

Light levels below the set threshold will not be recognized as peak waveforms.

Item	Setting value	Default value
Peak Selection Threshold	0 to 4095	250

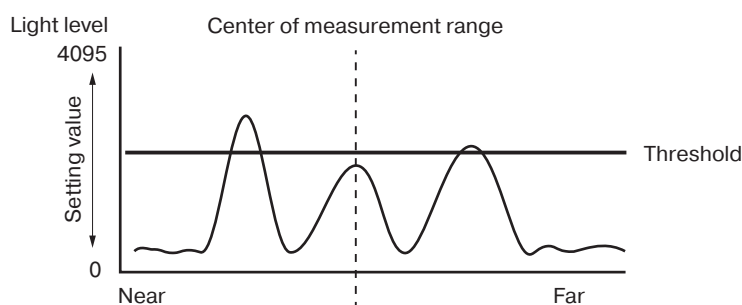

4-3 [B] Output 1 (Output 2)

* The settings for Output 2 cannot be changed by operating sensor. Please use IO-Link to change settings.
See "5-1-3 Service Data" on page 5-5.

4-3-1 [B1] Mode

Sets the control output for the measured value.

It also defines the relationship between the threshold or hysteresis and output.

Item	Setting value	Default value
Mode	1 point/Window/FGS 1-point/Light level error/2 point/OFF	1 point

■ 1 point

Output 1 turns off at a position at a distance equivalent to hysteresis from the position set through teaching or by the threshold.

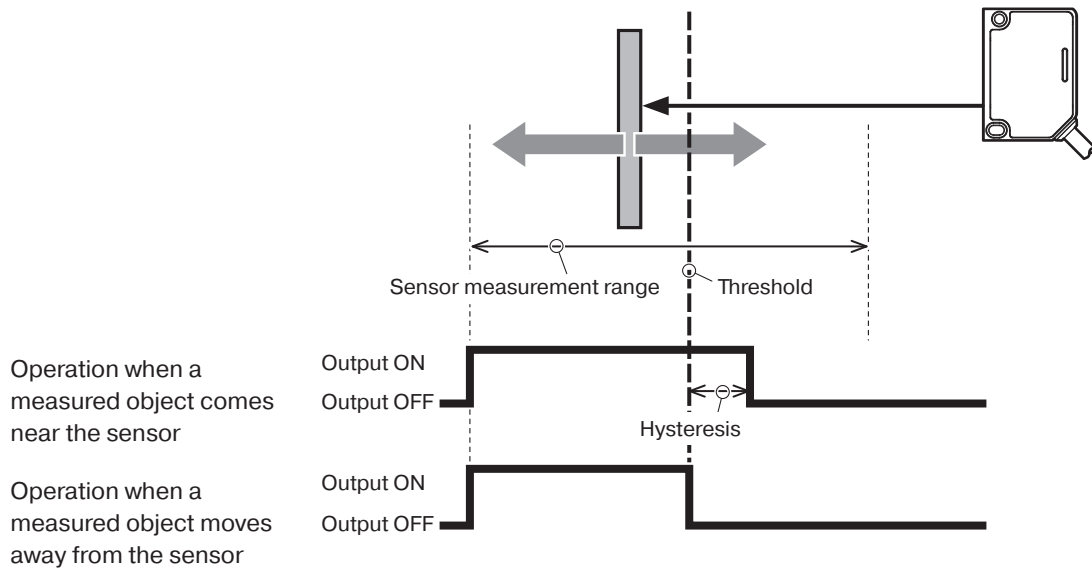

■ Window

Position set using Teach 1 Auto (first) or Threshold1.

Position set using Teach 2 Auto (second) or Threshold2.

Output 1 turns on between these two points. Operation will be suspended for the set hysteresis amount during operation with output turned off.

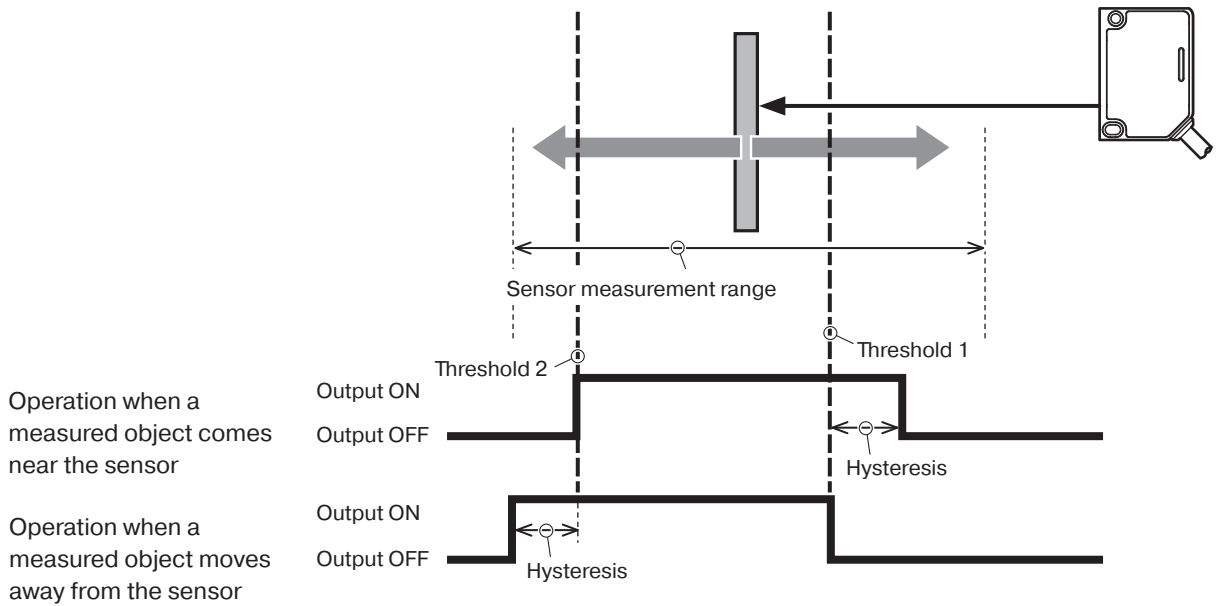

■ FGS 1-point

Control Output 1 turns off within an area equivalent to the tolerance set centered on the Threshold1 position (Output Mode: N.O.).

Operation will be suspended for the set hysteresis amount during operation with output turned off.

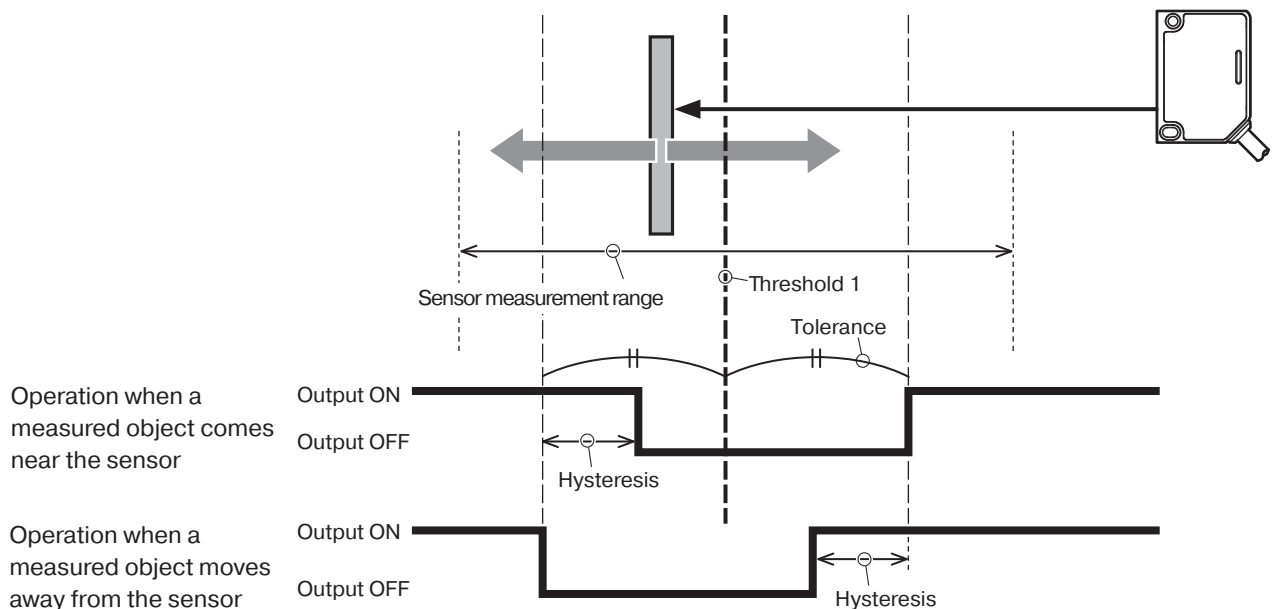

Light level error

Output when the light level (received light amount) is below the threshold.

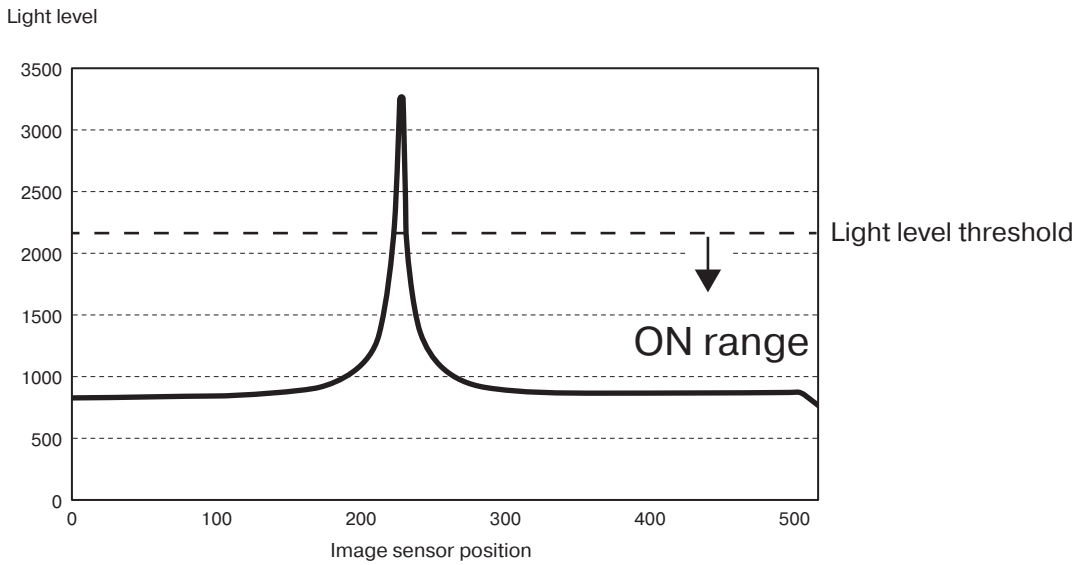

2 point

When the measured object approaches the sensor, output is turned on from the sensor measurement range to Threshold2.

When the measured object moves away from the sensor, output is turned on from Threshold1 to the sensor measurement range.

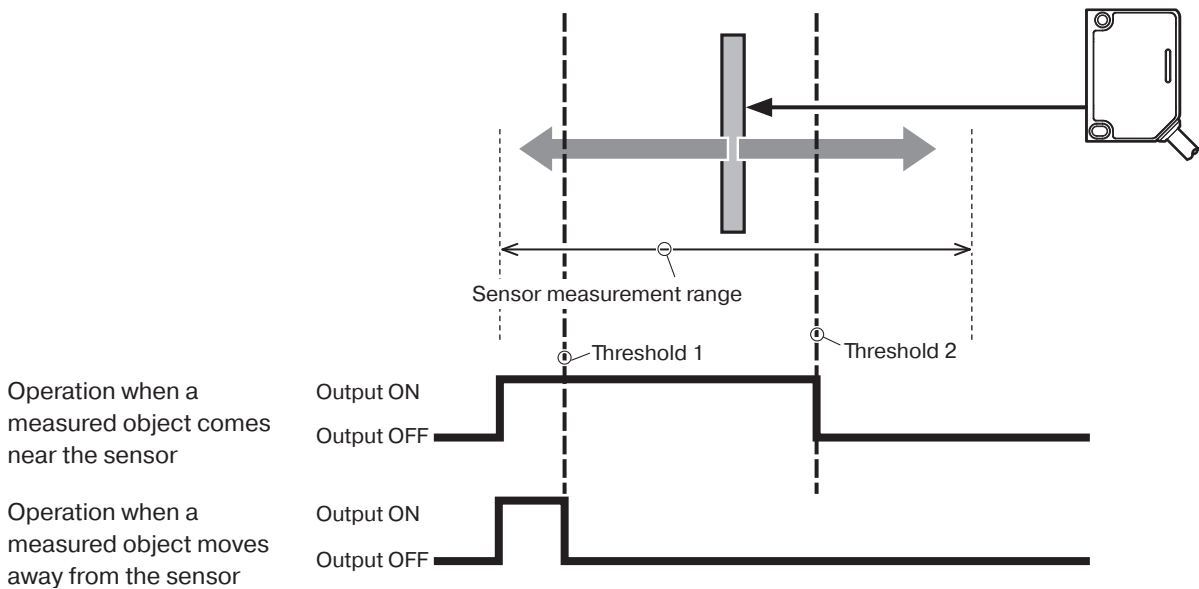

MEMO

When the unit is started, output will be turned OFF if the measured value is between Threshold 1 and Threshold 2.

OFF

Mode is not used.

4-3-2 [B2] Teach 1 Auto

Teach and save current measured value as Threshold1. (SP1=Switching Point 1)

4-3-3 [B3] Threshold1

Sets Threshold1 manually.

The threshold set in [B1] Mode can be finely calibrated.

Item	Selected mode	Setting value	Default value
Threshold1	1 point Window, FGS 1-point	-524.287 to +524.287 mm	CD2S-30x: -5.00 mm CD2S-50x: -15.00 mm CD2S-110x: -50.0 mm
	Light level error	0 to 4095	2048

4-3-4 [B4] Teach 2 Auto

Teach and save current measured value as Threshold2. (SP2=Switching Point 2)

This setting is only possible when Window mode and 2-point are selected in [B1] Mode.

4-3-5 [B5] Threshold2

Sets Threshold2 manually.

The threshold set in [B3] Mode can be finely calibrated.

Item	Setting value	Default value
Threshold2	-524.287 to +524.287 mm	CD2S-30x: +5.00 mm CD2S-50x: +15.00 mm CD2S-110x: +50.0 mm

4-3-6 [B6] Output Mode

Sets the output operation.

Item	Setting value	Default value
Output Mode	N.O./N.C.	N.O.

N.O.: Turns on at the side farthest from the threshold or within the range of Threshold1 and Threshold2.

N.C.: Turns off at the side farthest from the threshold or within the range of Threshold1 and Threshold2.

■ 1 point

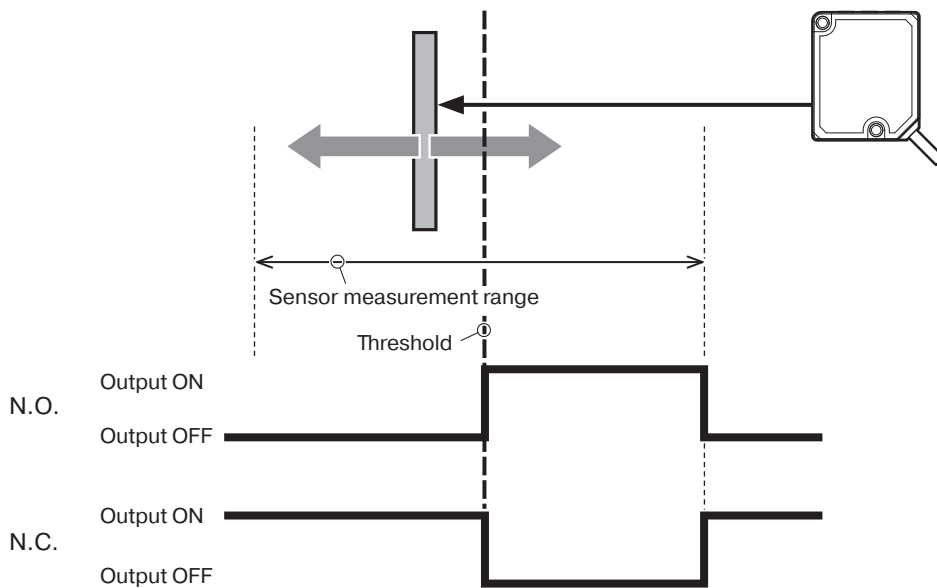

■ Window

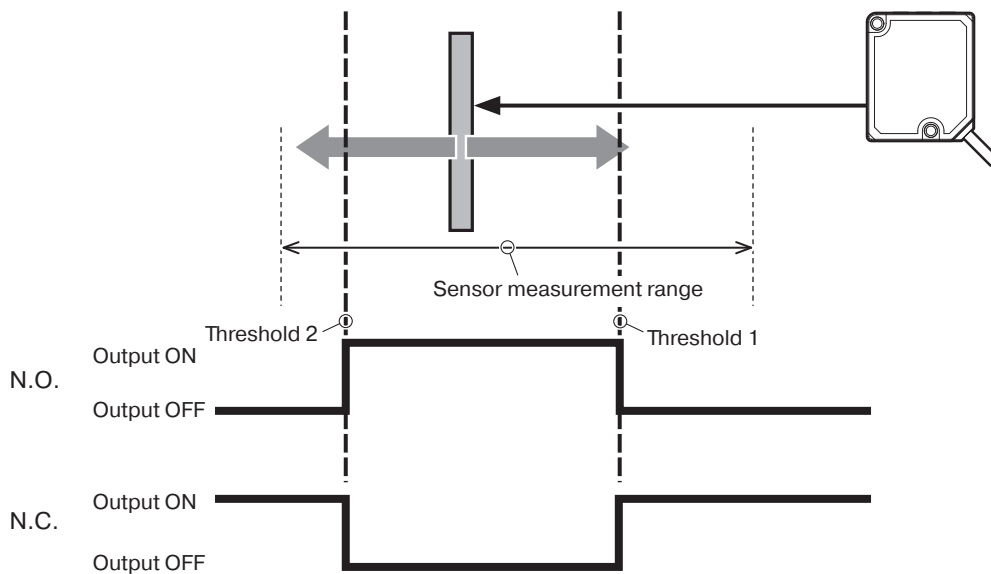

■ FGS 1-point

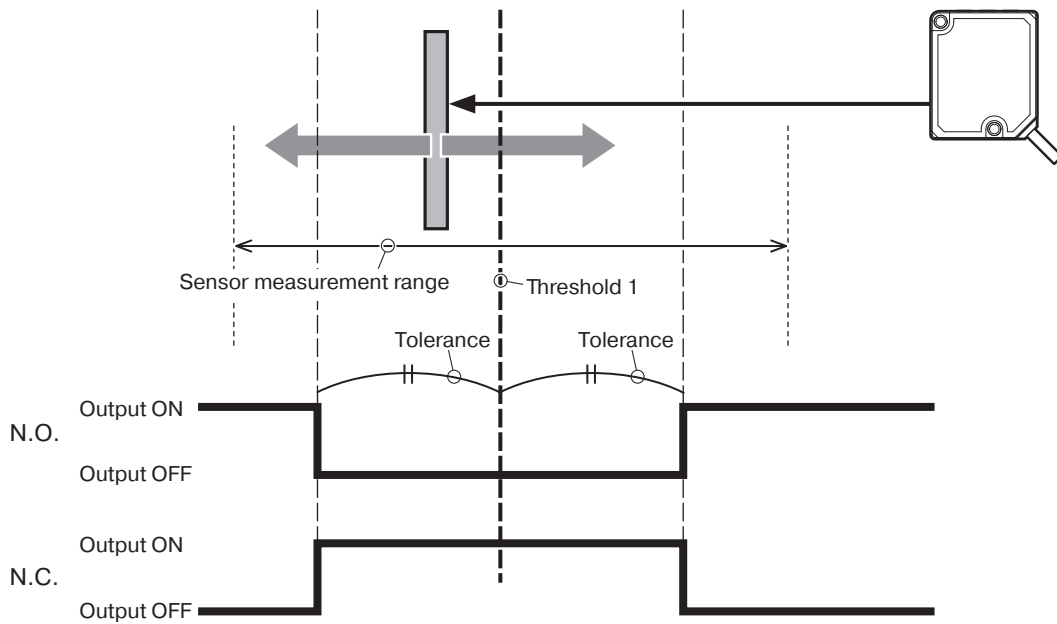

4-3-7 [B7] Delay Timer

Sets the delay timer for the control output.

Item	Setting value	Default value
Delay Timer	OFF/On Delay/Off Delay/On/Off Delay/One shot	OFF

■ On Delay

The output turns ON after the specified time delay after the judgment is turned ON.

If the judgment ON time is less than the ON delay time, as in the case of A, there will be no output.

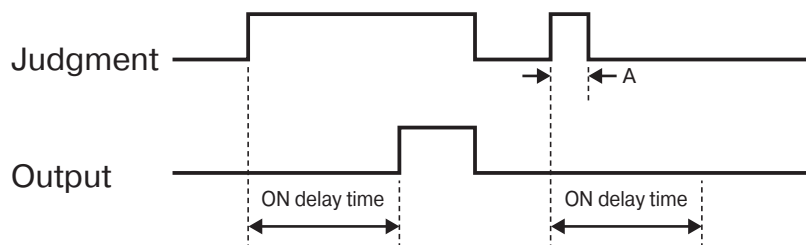

■ Off Delay

The control output turns OFF after the specified time delay after the judgment is turned OFF. If the judgment OFF time is less than the OFF delay time, as in the case of B, output will not turn OFF, but will remain ON.

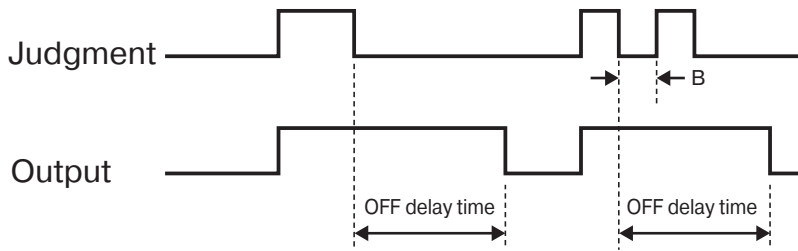

■ On/Off Delay

Mixed ON delay and OFF delay operation is performed.

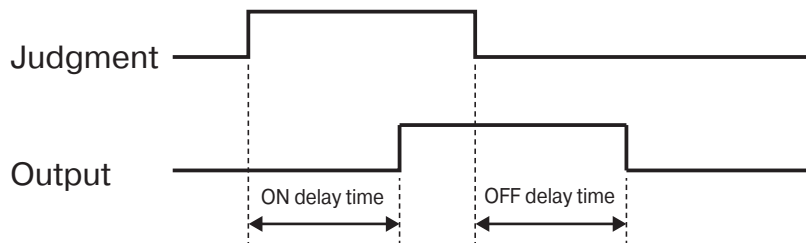

■ One shot

The control output is turned on for the specified time and then forcibly turned off.

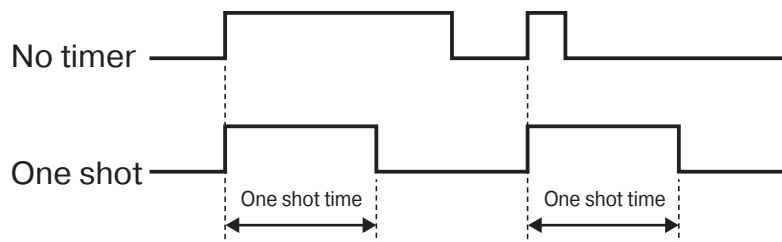

4-3-8 [B8] Timer Set

Sets the delay time for the mode set in [B7] Delay Timer.

For one-shot operation, this setting becomes the ON time instead of the delay time.

Item	Setting value	Default value
Timer Set	1 to 10000 ms	100 ms

4-3-9 [B9] Hysteresis

When the measured value approaches the threshold value (upper or lower) due to reasons such as measured object vibration, the control output may turn on/off repeatedly (chattering). When this happens, increase the hysteresis setting can prevent chattering.

Item	Setting value	Default value
Hysteresis	0 to +524.287 mm	CD2S-30x: +0.05 mm CD2S-50x: +0.15 mm CD2S-110x: +0.5 mm

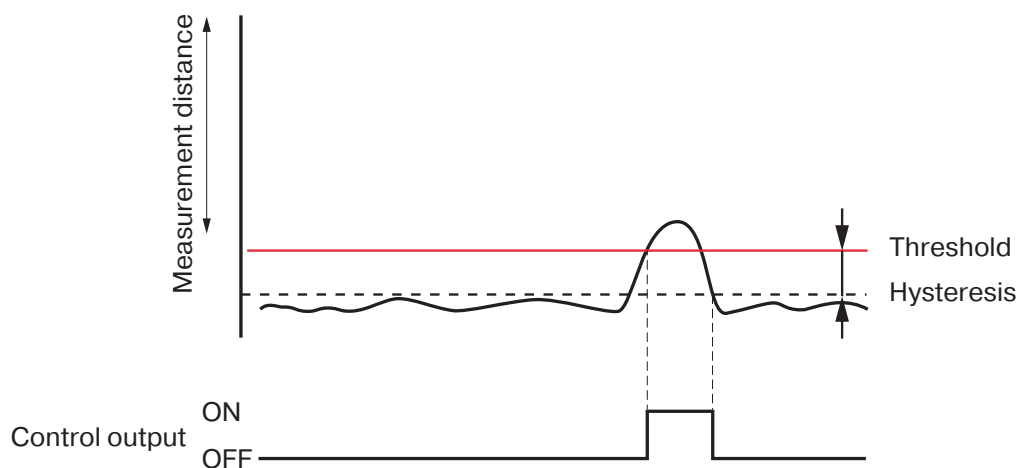

4-3-10 [B10] Tolerance

Sets an output range centered on the thresholds.

This setting is only possible when FGS 1-point is selected in [B1] Mode.

Item	Setting value	Default value
Tolerance	0 to 524.287 mm	CD2S-30x: 0.20 mm CD2S-50x: 0.60 mm CD2S-110x: 2.0 mm

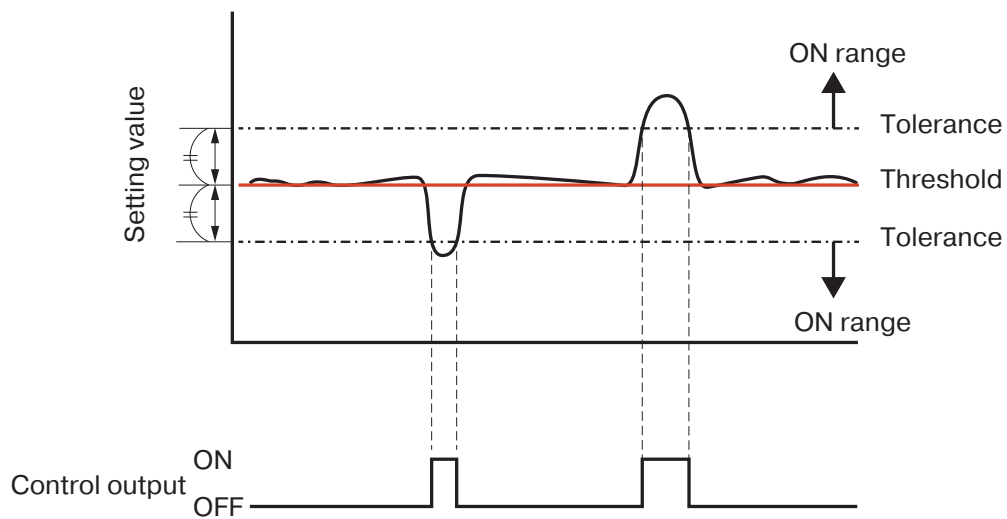

4-4 [C] Analog

When the measured value falls within the set analog output range, the analog output (current or voltage) corresponds to the measurement distance.

4-4-1 [C1] Analog Output

Selects the analog output type.

Item	Setting value	Default value
Analog Output	4...20 mA/0...10 V/OFF	4...20 mA

The settings menu display will change depending on the selected output type.

	Item	When 4...20 mA	When 0...10 V
C2	4 mA Teach	✓	
C3	4 mA Manual	✓	
C4	20 mA Teach	✓	
C5	20 mA Manual	✓	
C6	0 V Teach		✓
C7	0 V Manual		✓
C8	10 V Teach		✓
C9	10 V Manual		✓

4-4-2 [C2] 4 mA Teach

Press the key to teach and save current measured value as the 4 mA threshold (lower limit).

4-4-3 [C3] 4 mA Manual/[C5] 20 mA Manual

Edits and saves the threshold value saved using teaching or the existing setting value as desired.

Item	Setting value	Default value
4 mA Manual	-524.287 to +524.287 mm	CD2S-30x: -5.00 mm CD2S-50x: -15.00 mm CD2S-110x: -50.0 mm
20 mA Manual	-524.287 to +524.287 mm	CD2S-30x: +5.00 mm CD2S-50x: +15.00 mm CD2S-110x: +50.0 mm

4-4-4 [C4] 20 mA Teach

Press the key to teach and save current measured value as the 20 mA threshold (upper limit).

4-4-5 [C6] 0 V Teach

Press the key to teach and save current measured value as the 0 V threshold (lower limit).

4-4-6 [C7] 0 V Manual/[C9] 10 V Manual

Edits and saves the threshold value saved using teaching or the existing setting value as desired.

Item	Setting value	Default value
0 V Manual	-524.287 to +524.287 mm	CD2S-30x: -5.00 mm CD2S-50x: -15.00 mm CD2S-110x: -50.0 mm
10 V Manual	-524.287 to +524.287 mm	CD2S-30x: +5.00 mm CD2S-50x: +15.00 mm CD2S-110x: +50.0 mm

4-4-7 [C8] 10 V Teach

Press the key to teach and save current measured value as the 10 V threshold (upper limit).

4-5 [D] Input

Selects the operation of the external input terminal and sets the Input Mode and Input Hold Mode functions.

4-5-1 [D1] Input Function

Sets the external input operation.

Item	Setting value	Default value
Input Function	OFF/Threshold Teach/Analog Teach/Hold/Zero point Teach-in/Laser Off	OFF

■ OFF

The external input terminal is not used.

■ Threshold Teach

Uses the external input terminal as a teach input.

Performs teaching according to the setting value configured in [B1] Mode.

Mode	Operation when input signal is ON
1 point	Teaches Threshold1 when input signal is ON.
Window	Teaches Threshold1 when input signal turns ON for the first time, and teaches Threshold2 when it turns ON for the second time. Overwrites the Threshold1 taught at the first input signal when input signal turns ON for the third time.
FGS 1-point	Teaches Threshold1 when input signal is ON.
Light level error	Teaches Threshold1 (light level threshold) when input signal is ON.

■ Analog Teach

Uses the external input terminal as a teach input for analog output.

Teaches lower and upper limit values for any of the items set in [C1] Analog Output.

Analog output	Operation when input signal is ON
4 mA to 20 mA	Teaches 4 mA (lower limit) when input signal turns ON for the first time, and teaches 20 mA (upper limit) when it turns ON for the second time. When input signal turns ON for the third time, overwrites the 4 mA (lower limit) taught at the first input signal.
0 V to 10 V	Teaches 0 V (lower limit) when input signal turns ON for the first time, and teaches 10 V (upper limit) when it turns ON for the second time. When input signal turns ON for the third time, overwrites the 0 V (lower limit) taught at the first input signal.

■ Input Hold Mode

Uses the external input terminal as a hold input.

See “4-5-2 [D2] Input Hold Mode” on page 4-24 for details on the Input Hold Mode menu.

■ Zero point Teach-in

Uses the external input terminal as an offset input or for offset clearing.

Input Mode	Operation when input signal is ON
N.O.	Executes offset when input signal turns ON. Offset clear when OFF at an input signal ON time of 1,000 ms or more.
N.C.	Executes offset when input signal turns OFF. Offset clear when ON at an input signal OFF time of 1,000 ms or more.

■ Laser Off

Use the external input terminal as a laser Off input.

Input signal	Operation when input signal is ON
ON	Laser off when input signal turns ON.
OFF	Laser start when input signal turns OFF.

4-5-2 [D2] Input Hold Mode

When “Input Hold Mode” is selected for [D1] Input Function, the external input terminal is used as a hold input.

Item	Setting value	Default value
Input Hold Mode	Measured Value/Peak Value/Lowest Value	Measured Value

■ Measured value

When “N.O.” is selected for [D4] Input Mode, the measured value is held when the external input signal turns ON.

When “N.C.” is selected for [D4] Input Mode, the measured value is held when the external input signal turns OFF.

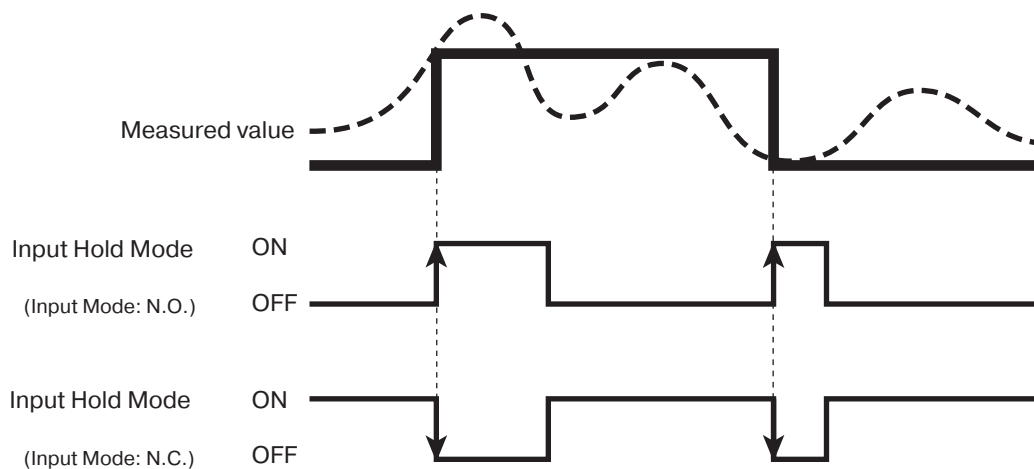

■ Peak Value

When “N.O.” is selected for [D4] Input Mode, the maximum measured value during the sampling period is held when the external input signal turns ON.

When “N.C.” is selected for [D4] Input Mode, the maximum measured value during the sampling period is held when the external input signal turns OFF.

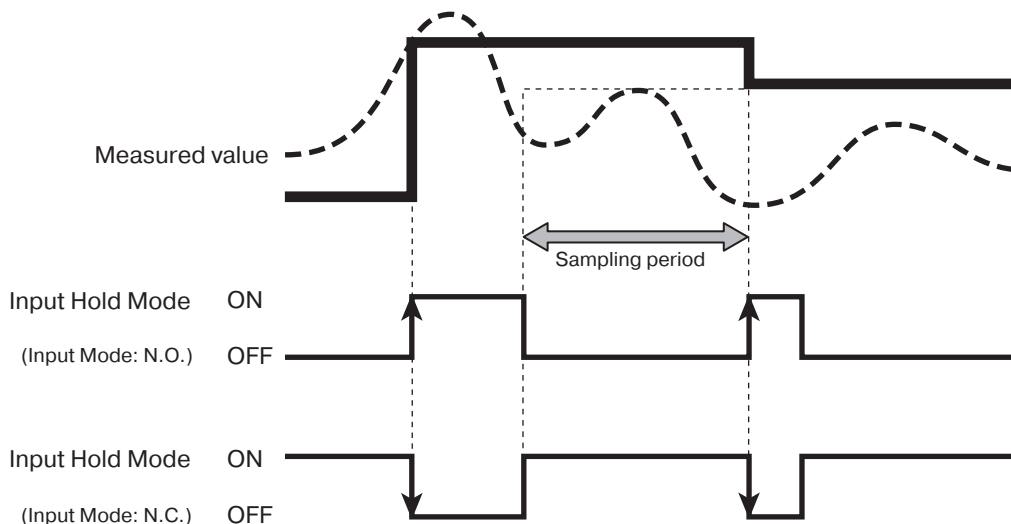

■ Lowest value

When “N.O.” is selected for [D4] Input Mode, the minimum measured value during the sampling period is held when the external input signal turns ON.

When “N.C.” is selected for [D4] Input Mode, the minimum measured value during the sampling period is held when the external input signal turns OFF.

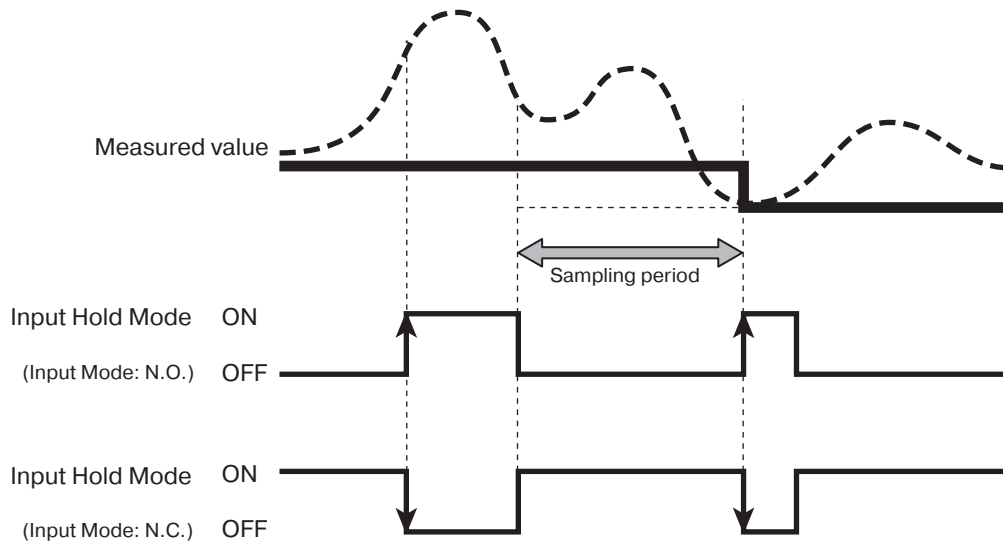

4-5-3 [D3] Input Delay

Operates as an input when the input continues for longer than the delay time (100 ms) when input delay is enabled.

This function prevents external inputs from turning on/off at high speed.

Item	Setting value	Default value
Input Delay	No/Yes	No

- No: Input delay OFF
- Yes: Input delay ON (100 ms)

* The minimum input time is 6 ms.

4-5-4 [D4] Input Mode

Sets the external input operation polarity.

Item	Setting value	Default value
Input Mode	N.O./N.C.	N.O.

N.O.: Trigger turns ON when external input is ON.

N.C.: Trigger turns OFF when external input is ON.

4-6 [E] Device

Configures various device settings (initialization, display language, no. of decimal places, inverted display, etc.).

4-6-1 [E1] Reset Factory Settings

Initializes the device and restores factory settings.

- No: Cancel initialization.
- Yes: Perform initialization.

Settings are initialized immediately after resetting to factory settings.

See “3-2 When turning on power for the first time” on page 3-7 for details on default settings.

4-6-2 [E2] Save Customer Settings

Saves the current settings as default values.

- No: Do not save the current settings.
- Yes: Save the current settings.

4-6-3 [E3] Apply Customer Settings

Apply the settings to the device using settings previously saved in [E2] Save Customer Settings.

- No: Do not apply the content saved in [E2] Save Customer Settings.
- Yes: Apply the content saved in [E2] Save Customer Settings.

MEMO

If no customer settings have been saved, default values will be used when executing Apply Customer Settings.

4-6-4 [E4] Reset Calibration

Initializes the calibration settings made in “4-2-10 [A11] Span Teach” on page 4-9.

- No: Cancel initialization.
- Yes: Perform initialization.

4-6-5 [E5] Language

Sets the display language.

Item	Setting value	Default value
Language	English/German/Spanish/Simplified Chinese/ Japanese/Traditional Chinese/Korean	Japanese

MEMO

This sub menu will remain in English even if the Language is changed.

4-6-6 [E6] Display Off Time

Sets the time until the display turns off after key operation stops.

Setting to Off will cause the OLED display to stay on, shortening the life of the component.

Set the display off time to 10 seconds or more whenever possible.

The OLED display will turn back on if any of the operation keys are pressed.

Item	Setting value	Default value
Display Off Time	OFF/10/20/60/300/1200/3600 sec	300 sec

4-6-7 [E7] Display Brightness

Sets the brightness of the display.

Item	Setting value	Default value
Display Brightness	10/20/30/40/50/60/70/80/90/100 %	30 %

4-6-8 [E8] Rotate Display

Sets the display orientation.

The standard orientation is with the [×] key toward the top.

Item	Setting value	Default value
Rotate Display	0/180	0

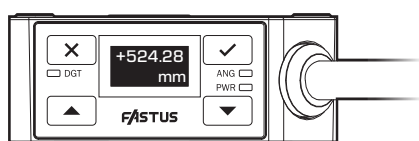

When set to 0

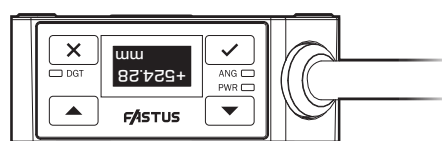

When set to 180

4-6-9 [E9] Laser

Manually turns the laser on or off.

Item	Setting value	Default value
Laser	ON/OFF	ON

- ON: Turns the laser on.
- OFF: Turns the laser off.

4-6-10 [E10] Output Polarity

Switches the control output type between PNP/NPN and Push-pull.

Item	Setting value	Default value
Output Polarity	PNP/NPN/PP	NPN

4-6-11 [E11] No of Decimal Places

Sets the number of decimal places shown on the display.

Item	Setting value	Default value
No of Decimal Places	0/0.1/0.01/0.001	CD2S-30x: 0.01 CD2S-50x: 0.01 CD2S-110x: 0.1

Measured values below the specified number of decimal places are rounded down.

Note

For the CD2S-110x, the number of decimal places cannot be set to 0.001.

4-7 [G] Information

Displays information about the device.

4-7-1 [G1] Model Number

Displays the model number.

4-7-2 [G2] Serial Number

Displays the serial number.

4-7-3 [G3] Firmware Version

Displays the firmware version.

4-7-4 [G4] Sensor Operating Hours

Displays the total sensor operation time. (Hours: Minutes)

4-7-5 [G5] Laser Operating Hours

Displays the total hours that the sensor laser has been in operation. (Hours: Minutes)

4-7-6 [G6] Internal Temperature

Displays the internal temperature of the sensor.

4-7-7 [G7] Error Counter

■ Error Counter Display

The number of errors is stored and displayed for up to 10 types of errors.

The number of errors is counted up to 256 times, with “256” being displayed for any subsequent errors.

The Error Counter display is as follows.

“Error number”: “Number of errors”: “Internal temperature at time of latest occurrence” and “Elapsed time since power ON (Hours:Minutes)”

Error numbers and their details are as follows.

Error number	Error details
1	Sensor high temp. (70°C or more)
2	Sensor low temp. (-20°C or less)
3	C/Q overcurrent detection (IO-Link models only)
4	IO-Link PHY high temperature detection (IO-Link models only)
5	Supply voltage upper limit error (26.4 V)
6	Supply voltage lower limit error (10.8 V)
7	Laser deterioration detection
8	Analog current output open circuit detection
9	Analog voltage output short circuit detection
10	Analog output overheat detection

Example: Analog current output: Open, Number of errors: 130, Temperature at time of occurrence: 37°C, Elapsed time since power ON: 15 hours

8: 130 37 15:0

Elapsed time since power ON
Internal temperature at the time of error occurrence
Number of errors
Error number

See “7-1-2 Error Causes and Troubleshooting” on page 7-2 for error causes and troubleshooting.

●●● MEMO ●●●

Error details displayed in [G7] Error Counter will not be cleared by resetting factory settings.

4-7-8 [G8] Error History

■ Error History Display

Up to 10 errors are stored and displayed for each type of error condition.

If an 11th error occurs, it is overwritten from the oldest error.

The Error History display is as follows.

“Error number”: “Error code” “Internal temperature at time of occurrence” “Sensor operating hours at time of occurrence” “Laser operating hours at time of occurrence”

Internal temperature at time of occurrence: Only the integer part of the internal temperature at the time the error occurred is displayed.

Sensor operating hours at time of occurrence: Only the sensor operating time (hours) at the time of error occurrence is displayed.

Laser emission time at time of occurrence: Only the laser operating time (hours) at the time of error occurrence is displayed.

Error codes and their details are as follows.

Error code	Error details
0x01	Sensor high temp. (70° C or more)
0x02	Sensor low temp. (-20° C or less)
0x03	C/Q overcurrent detection (IO-Link models only)
0x04	IO-Link PHY high temperature detection (IO-Link models only)
0x05	Supply voltage upper limit error (26.4 V)
0x06	Supply voltage lower limit error (10.8 V)
0x07	Laser deterioration detection
0x08	Analog current output open circuit detection
0x09	Analog voltage output short circuit detection
0x10	Analog output overheat detection

Example: Analog current output: Open, Internal temperature at the time of error occurrence: 37°C, Sensor operating hours at the time of error occurrence: 150 h, Laser operating hours at the time of error occurrence: 30 h

1: 8 37 150 30

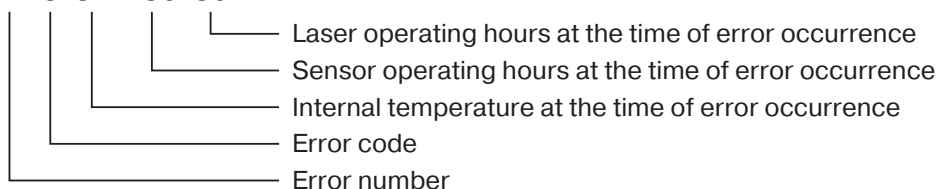

●●● MEMO ●●●

Error details displayed in [G8] Error History will not be cleared by resetting factory settings.

4-8 Quick Set Menu



Frequently used settings can be set directly from the measured value screen.

Main Menu display	Quick Set item	Reference page
Distance (abs.)	Zero point Teach-in	page 4-6
Distance (rel.)	Zero point Teach-in	page 4-6
Analog output	Analog Output	page 4-20
	4 mA Teach	4 mA Manual
	0 V Teach	0 V Manual
	20 mA Teach	20 mA Manual
	10 V Teach	10 V Manual
Received light waveform		page 3-5





5

IO-Link

This chapter introduces how to use the product as an IO-Link device.

5-1 Index list



5-1-1 Communication Specifications

Minimum cycle time		0.8 ms	
Baud rate		COM3 (230.4 kbps)	
M-Sequence code in Preoperate mode		TYPE_1_2	
M-Sequence code in Operate mode		Length of TYPE_2_V ON request data in bytes = 2	
ISDU Support		Yes	
IO-Link Revision		Ver.1.1.	
Number of process input data bytes		6byte	
Number of process output data bytes		1 byte	
Vendor ID		DEC: 1076	HEX: 0x0434
Device ID	20822 (CD2S-30M12)	DEC: 77831	HEX: 0x013007
	20823 (CD2S-50M12)	DEC: 77832	HEX: 0x013008
	20284 (CD2S-110M12)	DEC: 77833	HEX: 0x013009
	20980 (CD2S-30)	DEC: 77831	HEX: 0x013007
	20981 (CD2S-50)	DEC: 77832	HEX: 0x013008
	20982 (CD2S-110)	DEC: 77833	HEX: 0x013009

* Refrain from installing IODD using IODD Converter versions older than Ver.1.53.

5-1-2 Process data format

Process input data

Byte No.	Bit								Details
	7	6	5	4	3	2	1	0	
n+0	Measurement distance (signed, unit: μm) ^{*1}								-524287 to +524287
n+1									
n+2									
n+3									
n+4	Scale ^{*2}								CD2S-30x: -6 (0.001 mm) CD2S-50x: -6 (0.001 mm) CD2S-110x: -6 (0.001 mm)
n+5	Exposure time reached the measurement period	Estimated the waveform peak	Peak width error	Peak height error	Light level error	Peak detection error	Q2	Q1	Q1, Q2, peak detection error, light level error, peak height error, peak width error, waveform peak, exposure time [0: OFF, 1: ON]

*1 The measurement direction depends on the scale.

*2 Scale indicates 10^n .

The measurement directions in the table below have special meanings.

Measurement direction (16 bit)	Description
-2147483640	Outside the measurement range on the negative side
2147483640	Outside the measurement range on the positive side
2147483644	Outside the measurement range ^{*1}

*1 If the measurement direction is 2147483644, this is displayed when the received light waveform cannot be observed.

Process Input Data Word Assignment

Example: When using the IO-Link master UR series of OPTEX FA (default setting: ascending order (little endian))

Word No.	Byte	
	Higher order byte	Lower order byte
N+0	Process data n+4	Process data n+5
N+1	Process data n+2	Process data n+3
N+2	Process data n+0	Process data n+1

Word No.	Byte															
	15	14	13	12	11	10	9	8	7	6	5	4	3	2	1	0
N+0	Scale								Exposure time reached the measurement period	Estimated the waveform peak	Peak width error	Peak height error	Light level error	Peak detection error	Q2	Q1
N+1	Measurement distance (signed, unit: μm)															
N+2																

■ Process output data

Byte No.	Bit								0	Details
	7	6	5	4	3	2	1			
n+0	Reserved								Laser ON/OFF	Laser ON/OFF [0: ON, 1: OFF]

● Process Output data Word Assignment

Example: When using the IO-Link master UR series of OPTEx FA (default setting: ascending order (little endian))

Word No.	Byte	
	Higher order byte	Lower order byte
N+0	N/A	Process data n+0

Word No.	Byte															
	15	14	13	12	11	10	9	8	7	6	5	4	3	2	1	0
N+0	N/A								Reserved							Laser ON/OFF

5-1-3 Service Data

Name	Index number DEX (HEX)	Sub-index No.	Read/Write*1	Back-up	Format	Length in bytes	Default value	Setting Details	Remarks (Unit)
System Command	2 (0x02)	-	W	-	UINT	1	-	Executes the following functions depending on the written value. 65: SP1 Teach-in 66: SP2 Teach-in 80: Start firmware update sequence 81: Firmware update unlock command 1 82: Firmware update unlock command 2 126: Start device search 127: End device search 129: Reset application settings 131: Back-to-box 192: Save customer settings 193: Restore customer settings 194: Offset 195: Offset clear 196: Calibration	
Device Access Lock	12 (0x0C)	-	R/W	✓	UINT	2	0	For read access: bit 0: Unused bit 1: Unused bit 2: Unused bit 3: Key lock status For write access: bit 0: Unused bit 1: Unused bit 2: Unused bit 3: 1: Locked, 0: Unlocked	bit 4-15: System reserved
Profile	13 (0x0D)	-	R	-	UINT	12	0x0014 0x0031 0x4000 0x800C 0x8013 0x8101	Byte1-2 : Function ID 0x8101 Byte3-4 : Function ID 0x8013 Byte5-6 : Function ID 0x800C Byte7-8 : Profile ID 0x4000 Byte9-10 : Profile ID 0x0031 Byte11-12 : Profile ID 0x0014	
Process Data Input Format	14 (0x0E)	-	R	-	UINT	12	3, 32, 16 3, 8, 8 1, 8, 0		
Process Data Output Format	15 (0x0F)	-	R	-	UINT	3	1,1,0		
Vendor Name	16 (0x10)	-	R	-	STRINGS	16	-	"OPTEX FA"	
Vendor Information	17 (0x11)	-	R	-	STRINGS	64	-	www.optex-fa.com	
Product Model	18 (0x12)	-	R	-	STRINGS	18	-	CD2S-XXXXX	
Model Number	19 (0x13)	-	R	-	STRINGS	7	-	XXXXXXXX	
Product Function	20 (0x14)	-	R	-	STRINGS	45	-	"Displacement Sensor"	
Serial Number	21 (0x15)	-	R	-	STRINGS	16	-	XXXXXXXXXXXX	
Hardware Version	22 (0x16)	-	R	-	STRINGS	64	-	Responds with the hardware version.	
Firmware Version	23 (0x17)	-	R	-	STRINGS	64	-	Responds with the firmware version.	
User Tag Name	24 (0x18)	-	R/W	✓	STRINGS	32	*****	Reading: Responds with the set application tag. Writing: Sets the specified string as the application tag.	
Function Tag Name	25 (0x19)	-	R/W	✓	STRINGS	32	*****	Reading: Responds with the set function tag. Writing: Sets the specified string as the function tag.	
Location Tag Name	26 (0x1A)	-	R/W	✓	STRINGS	32	*****	Reading: Responds with the set location tag. Writing: Sets the specified string as the location tag.	
Error Count	32 (0x20)	-	R	-	UINT	2	0	Reads the error count.	Indicates the number of errors since the power was turned on. For the IO-Link specification, this will disappear when the power is turned off.

Name	Index number DEX (HEX)	Sub-index No.	Read/Write*1	Back-up	Format	Length in bytes	Default value	Setting Details	Remarks (Unit)		
Device Status	36 (0x24)	-	R	-	UINT	1	0	0: Device normal 1: Maintenance required 2: Conditions outside the guaranteed operating range (supply voltage/ambient temperature) 3: Function check 4: Error			
Detailed Device Status	37 (0x25)	-	R	-	UINT	9	0	EVENT code 0x4210: Sensor high temp. 0x4220: Sensor low temp. 0x7710: Short-circuit on output line	The data format for each error status is as follows. Byte 1: Event code (low-order) Byte 2: Event code (high-order) Byte 3: Specific information bit 0-2: Source (0 = Unknown, 4 = Application) bit 4-5: Type (1 = Notification, 2 = Warning, 3 = Fault) bit 6-7: Mode (1 = Single occurrence, 2 = Resolved, 3 = Occurrence)		
Process Data Input	40 (0x28)	-	R	-	INT			See "Process input data" on page 5-3.			
Process Data Output	41 (0x29)	-	R	-	INT	1	-	See "Process output data" on page 5-4.			
Teach Channel	58 (0x3A)	-	R/W	✓	UINT	1	-	1 : Q1 output 2 : Q2 output 192 : Qa output			
Teach Status	59 (0x3B)	-	R	-	UINT	1	-	bit 0-3: Teach Status bit 4: SP1 teach success/failure (1: Success, 0: Failure) bit 5: Unused bit 6: SP2 teach success/failure (1: Success, 0: Failure) bit 7: Unused			
Q1 Threshold	60 (0x3C)	0	R/W	✓	INT	8	-	Byte 1-4: SP1 threshold			
								Byte 5-8: SP2 threshold			
		SP1 Threshold	1	R/W	✓	INT	4	-5000	-524287 to +524287	CD2S-30x, Unit: nm	
									-15000	-524287 to +524287	CD2S-50x, Unit: nm
									-50000	-524287 to +524287	CD2S-110x, Unit: nm
SP2 Threshold	2	R/W	✓	INT	4	5000	-524287 to +524287	CD2S-30x, Unit: nm			
							15000	-524287 to +524287	CD2S-50x, Unit: nm		
							50000	-524287 to +524287	CD2S-110x, Unit: nm		
Q1 Settings	61 (0x3D)	0	R/W	✓	UINT	6	-	Byte1-4: Hysteresis			
								Byte5: Teach-in			
								Byte6: Output Mode			
Output Mode	1	R/W	✓	UINT	1	0	0: N.O. 1: N.C.				
Teach-in	2	R/W	✓	UINT	1	1	1 : 1 point 2 : Window 128 : FGS 1-point 131 : Light level error				
Hysteresis	3	R/W	✓	UINT	4	50	0 to 524287	CD2S-30x, Unit: nm			
							150	0 to 524287	CD2S-50x, Unit: nm		
							500	0 to 524287	CD2S-110x, Unit: nm		
Q1 Tolerance	4371 (0x1113)	-	R/W	✓	UINT	4	200	0 to 524287	CD2S-30x, Unit: nm		
								600	0 to 524287	CD2S-50x, Unit: nm	
								2000	0 to 524287	CD2S-110x, Unit: nm	
Q1 Delay Mode	1085 (0x43D)	-	R/W	✓	UINT	1	0	0: OFF 1: ON delay 2: OFF delay 3: ON/OFF delay 4: One shot			
Q1 Delay Time	1087 (0x43F)	-	R/W	✓	UINT	2	-	0 to 10000	Unit: ms		

Name	Index number DEX (HEX)	Sub-index No.	Read/Write*1	Back-up	Format	Length in bytes	Default value	Setting Details	Remarks (Unit)	
Q2 Threshold	62 (0x3E)	0	R/W	✓	INT	8	-	Byte1-4: SP1 threshold Byte5-8: SP2 threshold		
		SP1 Threshold	1	R/W	✓	INT	4	-5000	-524287 to +524287	CD2S-30x, Unit: nm
								-15000	-524287 to +524287	CD2S-50x, Unit: nm
								-50000	-524287 to +524287	CD2S-110x, Unit: nm
		SP2 Threshold	2	R/W	✓	INT	4	5000	-524287 to +524287	CD2S-30x, Unit: nm
								15000	-524287 to +524287	CD2S-50x, Unit: nm
50000	-524287 to +524287							CD2S-110x, Unit: nm		
Q2 Settings	63 (0x3F)	0	R/W	✓	UINT	6	-	Byte1-4: Hysteresis* Byte5: Teach-in Byte6: Output Mode	* A hysteresis value of 0 cannot be entered.	
		Output Mode	1	R/W	✓	UINT	1	0	0: N.O. 1: N.C.	
		Teach-in	2	R/W	✓	UINT	1	1	1 : 1 point 2 : Window 128 : FGS 1-point 131 : Light level error	
		Hysteresis	3	R/W	✓	UINT	4	50	0 to 524287	CD2S-30x, Unit: nm
								150	0 to 524287	CD2S-50x, Unit: nm
								500	0 to 524287	CD2S-110x, Unit: nm
Q2 Tolerance	4372 (0x1114)	-	R/W	✓	UINT	4	200	0 to 524287	CD2S-30x, Unit: nm	
							600	0 to 524287	CD2S-50x, Unit: nm	
							2000	0 to 524287	CD2S-110x, Unit: nm	
Q2 Delay Mode	1086 (0x43E)	-	R/W	✓	UINT	1	0	0: OFF 1: ON delay timer 2: OFF delay timer 3: ON/OFF delay timer 4: One shot		
Q2 Timer Setup	1088 (0x440)	-	R/W	✓	UINT	2	100	1 to 10000	Unit: ms	
Signal Level Threshold	176 (0xB0)	-	R/W	✓	INT	2	2048	Signal level threshold when "Light level error" is selected for Q1/Q2. Q1 and Q2 have a shared threshold.		
Analog Threshold	630 (0x276)	0	R/W	✓	UINT	8		Byte1-4: SP2 threshold Byte5-8: SP1 threshold		
		SP1 Threshold (4 mA, 0 V)	1	R/W	✓	UINT	4	-5000	-524287 to +524287	CD2S-30x, Unit: nm
								-15000	-524287 to +524287	CD2S-50x, Unit: nm
								-50000	-524287 to +524287	CD2S-110x, Unit: nm
		SP2 Threshold (20 mA, 10 V)	2	R/W	✓	UINT	4	5000	-524287 to +524287	CD2S-30x, Unit: nm
								15000	-524287 to +524287	CD2S-50x, Unit: nm
50000	-524287 to +524287							CD2S-110x, Unit: nm		
Analog Output	121 (0x79)	-	R/W	✓	UINT	1	16	0: OFF 16: Current output of 4...20 mA 17: Voltage output of 0-10 V		
External Input Settings	122 (0x7A)	-	R/W	✓	UINT	1	0	0: OFF 16: Laser OFF 17: Teach-in 80: Sample hold 81: Peak hold 82: Bottom hold 85: Zero point teach-in 86: Analog teach-in		

Name	Index number DEX (HEX)	Sub-index No.	Read/Write*1	Back-up	Format	Length in bytes	Default value	Setting Details	Remarks (Unit)
External Input Delay	4400 (0x1130)	-	R/W	✓	UINT	1	0	0: No delay 1: Delay	
External Input Polarity	1093 (0x445)	-	R/W	✓	UINT	1	0	0: N.O. 1: N.C.	
External Input Status	226 (0xE2)	-	R	-	UINT	1	-	bit 7 0: External input 1: No external input	
Temperature	153 (0x99)	0	R	-	INT	5	-	Byte1: Minimum temperature at this startup Byte2: Maximum temperature at this startup Byte3: Minimum temperature for the entire period Byte4: Maximum temperature for the entire period Byte5: Current temperature	Unit: °C
Current Temperature		1	R	-	INT	1	-	-128 to 127	Unit: °C
Maximum Temperature for the Entire Period		2	R	-	INT	1	-	-128 to 127	Unit: °C
Minimum Temperature for the Entire Period		3	R	-	INT	1	-	-128 to 127	Unit: °C
Maximum Temperature at This Startup		4	R	-	INT	1	-	-128 to 127	Unit: °C
Minimum Temperature at This Startup		5	R	-	INT	1	-	-128 to 127	Unit: °C
Received Light Amount	175 (0xAF)	-	R	-	UINT	2	-	Responds with the current light level.	
Exposure Time	177 (0xB1)	-	R	-	UINT	2	-	Responds with the exposure time.	Unit: μs
Operating Hours	190 (0xBE)	0	R	-	UINT	8	-	Byte1-4: Laser operating hours Byte5-8: Sensor operating hours	
Sensor Operating Hours		1	R	-	UINT	4	-	0 to 1000000	Unit: Hours
Laser Operating Hours		2	R	-	UINT	4	-	0 to 1000000	Unit: Hours
Device Tag	64 (0x40)	-	R/W	✓	STRINGS	32	*****	Reading: Responds with the set device tag. Writing: Sets the specified string as the device tag.	
Device ID	16000 (0x3E80)	-	R/W		UINT	4	-		Used to maintain backward compatibility during future main version upgrades
Firmware Version	4534 (0x11B6)	0	R	-	UINT	38		Byte1-19: Firmware build date and time Byte20-38: Firmware version	
Firmware Version		1	R	-	UINT	19		Responds with the firmware version in X.X.X format.	
Firmware Build Date and Time		2	R	-	UINT	19		Responds with the firmware build date and time.	
Event Notification Handling	227 (0xE3)	-	R/W	✓	UINT	1	-	0: All events enabled 1: All events disabled 2: Events enabled, Process data invalid flag disabled 3: Events disabled, Process data invalid flag enabled	

Name	Index number DEX (HEX)	Sub-index No.	Read/Write*1	Back-up	Format	Length in bytes	Default value	Setting Details	Remarks (Unit)
Error History	4389 (0x1125)	0	R	-	UINT	130	-	Byte1-13: 10th error history Byte14-26: 9th error history Byte27-39: 8th error history Byte40-52: 7th error history Byte53-65: 6th error history Byte66-78: 5th error history Byte79-91: 4th error history Byte92-104: 3rd error history Byte105-117: 2nd error history Byte118-130: 1st error history	
1st Error History		1	R	-	UINT	13	-	1st error history	
2nd Error History		2	R	-	UINT	13	-	2nd error history	
3rd Error History		3	R	-	UINT	13	-	3rd error history	
4th Error History		4	R	-	UINT	13	-	4th error history	
5th Error History		5	R	-	UINT	13	-	5th error history	
6th Error History		6	R	-	UINT	13	-	6th error history	
7th Error History		7	R	-	UINT	13	-	7th error history	
8th Error History		8	R	-	UINT	13	-	8th error history	
9th Error History		9	R	-	UINT	13	-	9th error history	
10th Error History		10	R	-	UINT	13	-	10th error history	
Error Counter	4390 (0x1126)	0	R	-	UINT	80	-	Byte1-8: Analog output overheat detection Byte9-16: Analog voltage output short circuit detection Byte17-24: Analog current output open circuit detection Byte25-32: Laser deterioration detection Byte33-40: Supply voltage lower limit error Byte41-48: Supply voltage upper limit error Byte49-56: IO-Link PHY high temp Byte57-64: Short-circuit on output line Byte65-72: Low temp error Byte73-80: High temp error	
High Temp Error		1	R	-	UINT	8	-	Data formats are as follows: Byte 1: Error code Byte 2-3: Number of errors Byte 4: Internal temperature at the time of last error occurrence Byte 5-8: Operating time since start at the time of last error occurrence	
Low Temp Error		2	R	-	UINT	8	-		
Short-Circuit on Output Line		3	R	-	UINT	8	-		
IO-Link PHY High Temp		4	R	-	UINT	8	-		
Supply Voltage Upper Limit Error		5	R	-	UINT	8	-		
Supply Voltage Lower Limit Error		6	R	-	UINT	8	-		
Laser Deterioration Detection		7	R	-	UINT	8	-		
Analog Current Output Open Circuit Detection		8	R	-	UINT	8	-		
Analog Voltage Output Short Circuit Detection		9	R	-	UINT	8	-		
Analog Output Overheat Detection		10	R	-	UINT	8	-		

Name	Index number DEX (HEX)	Sub-index No.	Read/Write*1	Back-up	Format	Length in bytes	Default value	Setting Details	Remarks (Unit)
Pixel Data (0-115)	4360 (0x1108)	-	R	-	UINT	232	-	Responds with the received light waveform for pixels 0 to 115.	
Pixel Data (116-230)	4361 (0x1109)	-	R	-	UINT	232	-	Responds with the received light waveform for pixels 116 to 230.	
Pixel Data (231-346)	4362 (0x110A)	-	R	-	UINT	232	-	Responds with the received light waveform for pixels 231 to 346.	
Pixel Data (347-462)	4363 (0x110B)	-	R	-	UINT	232	-	Responds with the received light waveform for pixels 347 to 462.	
Pixel Data (463-511)	4364 (0x110C)	-	R	-	UINT	96	-	Responds with the received light waveform for pixels 463 to 511.	
Measurement Distance	229 (0xE5)	0	R	-	UINT	5	-	Byte1: Measurement distance information Byte2-5: Measurement distance data	
Measurement Distance Data		1	R	-	INT	4	-	Measurement distance data	
Measurement Distance Information		2	R	-	UINT	1	-	Measurement distance information 0: Within measurement range 1: Outside measurement range (upper limit error) 2: Outside measurement range (lower limit error) 3: No information	
Analog Value	635 (0x27B)	-	R	-	FLOAT ²	4		Responds with the analog current/voltage value being output. Current output: Responds with a real number in mA units. Voltage output: Responds with a real number in V units.	
Mask Range Settings	4367 (0x110F)	0	R/W	✓	UINT	8	-	Byte1-4: Mask near Byte5-8: Mask far	
Mask Near		1	R/W	✓	UINT	4	-5500	-5500 to 5500	CD2S-30x, Unit: nm
							-16500	-16500 to 16500	CD2S-50x, Unit: nm
							-53000	-53000 to 53000	CD2S-110x, Unit: nm
Mask Far		2	R/W	✓	UINT	4	5000	-5500 to 5500	CD2S-30x, Unit: nm
							16500	-16500 to 16500	CD2S-50x, Unit: mm
	53000						-53000 to 53000	CD2S-110x, Unit: mm	
Sampling Measurement	4368 (0x1110)	-	R/W	✓	UINT	2	1000	0: Auto 333: 333 μs 500: 500 μs 1000: 1 ms 2000: 2 ms 4000: 4 ms 8000: 8 ms 16000: 16 ms	
Peak Select	4369 (0x1111)	-	R/W	✓	UINT	1	0	0: OFF 1: Negative 2: Positive	
Moving Average	4373 (0x1115)	0	R/W	✓	UINT	2	16	0: OFF 4: 4 times 16: 16 times 64: 64 times 128: 128 times	
Median Filter	4374 (0x1116)	-	R/W	✓	UINT	2	7	0: OFF 3: 3 times 7: 7 times 15: 15 times	
Measurement Display	4375 (0x1117)	0	R/W	✓	UINT	1		0: Positive 1: Negative	
Measured Value Offset	4376 (0x1118)	0	R/W	✓	INT	4	0	-400000 to 400000	Measured value offset
Error Suppression Time	4377 (0x1119)	-	R/W	✓	UINT	4		Error suppression time	
Substitute Value	4378 (0x111A)	0	R/W	✓	INT	4	999999	-999999 to 999999	Units: nm

Name	Index number DEX (HEX)	Sub-index No.	Read/Write*1	Back-up	Format	Length in bytes	Default value	Setting Details	Remarks (Unit)
Error Mode	4379 (0x111B)	-	R/W	✓	UINT	1	-	Error Mode setting 0: Display substitute value 1: Keep previous value 2: Keep previous value + Timer	
Calibration Factor	4381 (0x111D)	-	R/W	✓	Floating point ²	4	-	Specify a range from -2.0 to 2.0. However, 0 cannot be specified.	
Peak Width	4384 (0x1120)	-	R	-	UINT	2	-	Received light waveform peak width	
Peak Selection Threshold	4397 (0x112D)	-	R/W	✓	UINT	2	250	Light level threshold for Peak Select	
MDC Overview	16512 (0x4080)	0	R	-	UINT	11	-	Byte1-4: Minimum MDC value Byte5-8: Maximum MDC value Byte9-10: Unit code Byte11: Scale value	
Minimum MDC Value		1	R	-	INT	4	-	25000 (50 mm type) 35000 (50 mm type) 60000 (110 mm type)	Minimum value of the numerical expression handled in the process data
Maximum MDC Value		2	R	-	INT	4	-	35000 (30 mm type) 65000 (50 mm type) 160000 (110 mm type)	Maximum value of the numerical expression handled in the process data
Unit Code		3	R	-	UINT	2	1010	1010 = m	
Scale Value		4	R	-	INT	1	-6	-6 (0.01)	CD2S-30x CD2S-50x CD2S-110x
Signal Quality Information	4399 (0x112F)	0	R	-	UINT	1	-	Bit 5: Peak detection error Bit 4: Signal level error Bit 3: Peak height error Bit 2: Peak shape error Bit 1: Peak interference error Bit 0: Exposure time error	
Peak Detection Error		1	R	-	UINT	1	-	0: Low 1: High	
Signal Level Error		2	R	-	UINT	1	-	0: Low 1: High	
Peak Height Error		3	R	-	UINT	1	-	0: Low 1: High	
Peak Shape Error		4	R	-	UINT	1	-	0: Low 1: High	
Peak Interference Error		5	R	-	UINT	1	-	0: Low 1: High	
Exposure Time Error		6	R	-	UINT	1	-	0: Low 1: High	
Adjusted Measurement Value	4396 (0x112C)	-	R/W	✓	INT	4		-10000 to 10000	The reference measurement value before Span Teach adjustment is set using "System Command: 196."

Name	Index number DEX (HEX)	Sub-index No.	Read/Write*1	Back-up	Format	Length in bytes	Default value	Setting Details	Remarks (Unit)
Display	234 (0xEA)	0	R/W		UINT	5	-	Byte1: No of Decimal Places Byte2: Language Byte3: Rotate display Byte4: Energy saving mode Byte5: Display brightness	
Display Brightness		1	R/W		UINT	1	30	10: 10% 20: 20% 30: 30% 40: 40% 50: 50% 60: 60% 70: 70% 80: 80% 90: 90% 100: 100%	
Energy Saving Mode		2	R/W		UINT	2	300	0: OFF 10: 10 sec 20: 20 sec 60: 60 sec 300: 300 sec 1200: 1200 sec 3600: 3600 sec	
Rotate Display		3	R/W		UINT	1	0	0: 0° 1: 180°	
Language		4	R/W	✓	UINT	1	3	0: English 1: German 2: Spanish 3: Japanese 4: Simplified Chinese 5: Traditional Chinese 6: Korean	
No of Decimal Places		5	R/W	✓	UINT	1	-	0: 0 1: 0.1 2: 0.01 3: 0.001	

*1 R: Read only, W: Write only, R/W: Read/Write

*2 Floating point representation is in accordance with the IEEE734 standard.

5-2 Events and Errors



5-2-1 Events

Code		Description
DEC	HEX	
16912	0x4210	High temp error
16928	0x4220	Low temp error
30480	0x7710	Short-circuit on output line
36001	0x8CA1	Setting value change notification

5-2-2 Error function

Code		Description
DEC	HEX	
32768	0x8000	Application error
32785	0x8011	Invalid index specified
32786	0x8012	Invalid subindex specified
32803	0x8023	Access denied
32816	0x8030	Parameter out of range
32817	0x8031	Parameter upper limit error
32818	0x8032	Parameter lower limit error
32819	0x8033	Parameter length upper limit error
32820	0x8034	Parameter length lower limit error
32832	0x8040	Invalid parameter

5-3 IO-Link Master UR Series Connection Settings



5-3-1 Functions When Connecting the CD2S and the UR

■ Checking the connected model name on the process data monitor

The model number, such as CD2S-110, will be shown on the display of the IO-Link Master UR series at No. P1.

■ Checking measured values and received light amounts on the process data monitor

Process data can be displayed at No. P3.

* For information on operation settings for “Process Data Monitor” and “Device Settings”, see the IO-Link Master UR series user’s manual Installation and Basic Settings Edition.

■ Backing up/restoring CD2S settings to the UR

CD2S settings can be backed up to the IO-Link Master UR Series.

Settings backed up to the UR can be downloaded to the CD2S.

* Restore and backup can be performed automatically or manually. *

For information on operation settings, see the IO-Link Master UR series user’s manual Installation and Basic Settings Edition.

■ Changing CD2S settings from the UR

CD2S settings can be checked and changed on the “?-3 Device Setting Value menu” of the UR Series.

● Checking Device Information

Standard Index

Number	Setting item	Description	Read/Write
S16	Vendor Name	Reads the value of index number 16 and displays it as a string.	R
S17	Vendor Information	Reads the value of index number 17 and displays it as a string.	R
S18	Product Model	Reads the value of index number 18 and displays it as a string.	R
S19	Model Number	Reads the value of index number 19 and displays it as a string.	R
S20	Product Function	Reads the value of index number 20 and displays it as a string.	R
S21	Serial Number	Reads the value of index number 21 and displays it as a string.	R
S22	Hardware version	Reads the value of index number 22 and displays it as a string.	R
S23	Firmware version	Reads the value of index number 23 and displays it as a string.	R
S24	User tag name	Reads the value of index number 24 and displays it as a string.	R/W

Manually Configuring Settings

Settings can be read and written by specifying any index number not listed in the standard index.

Number	Setting item	Description	Read/Write
S1	Read index	Used to access a device by directly specifying its index number (DEX). However, index number 3 has restricted access due to IO-Link regulations.	R/W
S2	Subindex	Set only if the index specified in “S1 Read index” has a subindex.	R/W
S3	Data format	Specifies the data format of the settings for the index to be accessed. Select from INT, UINT, STRINGS, HEX, and Floating point.	R/W
S4	Read data	Displays the read data. “-----” is displayed when a read error occurs. In the case of writable indexes, settings can be edited by pressing the ENTER key. Press the ENTER key again to write	R/W

* For information on operation settings, see the IO-Link Master UR series user’s manual Installation and Basic Settings Edition.

● Device settings

In the case of the CD2S series, settings in the table below are possible when not using IODD.

Default values are the same as those in the settings menus.

Number	Setting items	Description	Setting value
D1	Reset		Factory Reset/Save Customer Settings/Apply Customer Settings
D2	Cycle time		AUTO/0.333 ms/0.5 ms/1 ms/2 ms/4 ms/8 ms/16 ms
D3	Average filter		OFF/4/16/64/128
D4	Median filter		OFF/3/7/15
D5	Distance direction		Far+/Near+
D6	Measurement offset		-400.000 to 400.000 mm
D7	Substitute value		-999.999 to 999.999 mm
D8	Q1 Teach-in		Single point/Window/FGS 1-point/Signal level warning/Two point/OFF
D9	Q1 Teach SP1	Sets Q1 Teach 1 Manual.	-524.287 to 524.287 mm
D10	Q1 Teach SP2	Sets Q1 Teach 2 Manual.	-524.287 to 524.287 mm
D11	Q1 Polarity		N.O./N.C.
D12	Q1 Delay mode		OFF/ON delay/OFF delay/ON/OFF delay/One shot
D13	Q1 Delay time		1 to 10000 ms
D14	Q1 Tolerance		0 to 524.287 mm
D15	Q1 Hysteresis		0 to 524.287 mm
D16	Q2 Teach-in		Single point/Window/FGS 1-point/Signal level warning/Two point/OFF
D17	Q2 Teach SP1	Sets Q2 Teach 1 Manual.	-524.287 to 524.287 mm
D18	Q2 Teach SP2	Sets Q2 Teach 2 Manual.	-524.287 to 524.287 mm
D19	Q2 Polarity		N.O./N.C.
D20	Q2 Delay mode		OFF/ON delay/OFF delay/ON/OFF delay/One shot
D21	Q2 Delay time		1 to 10000 ms
D22	Q2 Tolerance		0 to 524.287 mm
D23	Q2 Hysteresis		0 to 524.287 mm
D24	IN mode		OFF/Laser OFF/Teach-in/Sample hold/Peak hold/Bottom hold/Zero point teach-in/Analog teach-in
D25	IN logic		N.O./N.C.
D26	Temperature		-128 to 127 deg C
D27	Sensor operating hours	Displays the operation time of the sensor. (Unit: hour)	
D28	Laser operating hours	Displays the operation time of the laser. (Unit: hour)	
D29	Firmware version	Displays the firmware version.	



6

Specifications

This chapter describes the specifications, dimension drawings, and other characteristics of this product.

6-1 Specifications

6-1-1 Measurement specifications

Model	Cable	CD2S-30	CD2S-50	CD2S-110
	Pigtail cable	CD2S-30M12	CD2S-50M12	CD2S-110M12
Center of measurement range		30 mm	50 mm	110 mm
Measurement range		±5 mm	±15 mm	±50 mm
Light source	Medium	Red semiconductor laser		
	Wavelength	655 nm		
	Maximum output	0.39 mW		
Laser class	JIS/IEC/FDA*1	CLASS 1		
Spot size*2		Approx. 0.2 x 0.5 mm	Approx. 0.3 x 0.7 mm	Approx. 0.5 x 1.6 mm
Linearity	White ceramic	±0.1% of F.S.	±0.1% of F.S.	±0.1% of F.S.
	Black ceramic	±0.3% of F.S.	±0.3% of F.S.	±0.3% of F.S.
Resolution*3		2 μm	5 μm	20 μm
Repeat accuracy*4		2 μm	5 μm	20 μm
Sampling period		333 μs/500 μs/1 ms/2 ms/4 ms/8 ms/16 ms/Auto		
Temperature drift*5		±0.03% of F.S./°C		
Weight (including cable)		Cable model: Approx. 130 g, Pigtail cable model: Approx. 60 g		

6-1-2 Common Specifications

Supply voltage		18 to 24 VDC (±10%, including ripple)
Current consumption		70 mA (at 24 VDC)
IO-Link	Specifications	Ver. 1.1
	Baud rate	COM3 (230.4Kbps)
	Number of process input data bytes	6byte
	Minimum cycle time	0.8 ms
Control output	No. of outputs	1 (Can be switched to IO-Link.)
	Type	NPN/PNP open collector or Push-Pull (selectable by setting) Max. 100 mA/24 VDC, residual voltage 1.8 V or less
Analog output	Current	4 ... 20 mA, load impedance: 300 Ω or less
	Voltage	0 ... 10 V, output impedance: 100 Ω or less
External input		Switchable between OFF/Threshold Teach/Analog Teach/Hold/Zero point Teach-in /Laser Off

Display	60 x 32 dot OLED display, Menu languages: English/Germany/Spanish/Japanese/Simplified Chinese/Traditional Chinese/Korean	
Indicators	Power indicator: Power on (lit green), IO-Link communication (blinking green) Output indicator: When control output is ON (lit orange), When error (blinking red) Analog output indicator: When analog output is ON (lit orange), Laser OFF (blinking red)	
Connection type	Cable type: \varnothing 5.5 mm 2 m cable Pigtail cable: \varnothing 5.5 mm 300 mm cable with M12 5-pin connector Minimum bending radius: Cable diameter \times 2 (when fixed in place), cable diameter \times 6 (when movable)	
Protection circuit	Reverse connection protection, overcurrent protection	
Environmental resistance	Degree of protection	IP67 (IEC 60529)
	Ambient temperature/humidity	-10 ... +50°C/35 ... 85%RH (without freezing or condensation)
	Storage temperature/humidity	-20 ... +60°C/35 ... 85%RH (without freezing or condensation)
	Ambient illuminance	Incandescent light: 10,000 lx Max. Fluorescent light: 10,000 lx Max.
	Vibration resistance	10 ... 55 Hz Double amplitude 1.5 mm, 2 hours in each X, Y, Z direction
	Shock resistance	500 m/s ² 3 times in each X, Y, Z direction
Applicable regulations	EMC	EU EMC Directive (2014/30/EU), UK EMC (Electromagnetic Compatibility Regulations 2016)
	Environment	RoHS Directive (2011/65/EU), UK RoHS (The Restriction of the Use of Certain Hazardous Substances in Electrical and Electronic Equipment Regulations 2012), China RoHS (MIIT Order No. 32)
	Safety	FDA Regulations (21 CFR 1040.10 and 1040.11) ^{*6}
Applicable standards	IEC 61000-6-2, IEC 61000-6-3, IEC 60825-1	
NRTL certification	UL Listed Certification for the U.S. and Canada	
Warm-up time	Approx. 10 minutes	
Material	Housing: Al, Front window: PMMA	

● Measurement Conditions

The measurement conditions are as follows unless otherwise designated:

Ambient temperature: 25°C (room temperature); supply voltage: 24 VDC; sampling period: 1 ms; moving average performed: 16 times; median filter: 7; center of measurement range, standard measured object (white ceramic) Furthermore, the sensor is fixed in place with an aluminum bracket when measurements are performed.

*1: In accordance with the FDA provisions of Laser Notice No. 56, the laser is classified per the IEC 60825-1:2014 standard.

*2: Defined with center strength $1/e^2$ (13.5%) at the center of the measurement range. There may be leak light other than the specified spot size. The sensor may be affected when there is a highly reflective object close to the detection area.

*3: The smallest determinable step when changing the distance between the sensor and the target one step at a time (at moving average of 128).

*4: Peak to peak value of measurement in stationary state (at moving average of 128).

*5: Typical example when the object (white ceramic) is measured while the object and the sensor are fixed in place with aluminum brackets.

This object is placed at the center of the measurement range.

*6: Excluding differences per Laser Notice No. 56.

6-2 Dimension Drawings

■ Cable types

(Unit: mm)

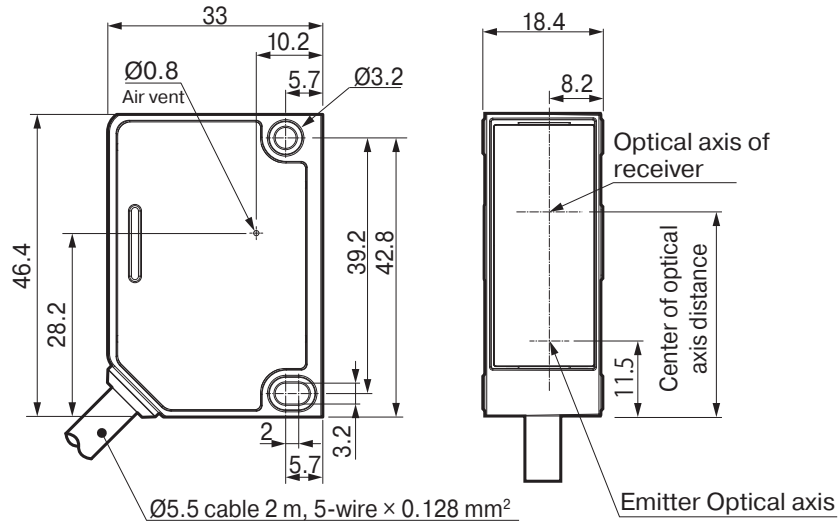

Center of optical axis distance per model

Units: mm

Model	CD2S-30(M12)	CD2S-50(M12)	CD2S-110(M12)
Distance to optical axis of receiver	27.3	29	30.3

■ Pigtail cable types

Ø5.5 cable, 5-wire x 0.128 mm²

M12
5 pin connector

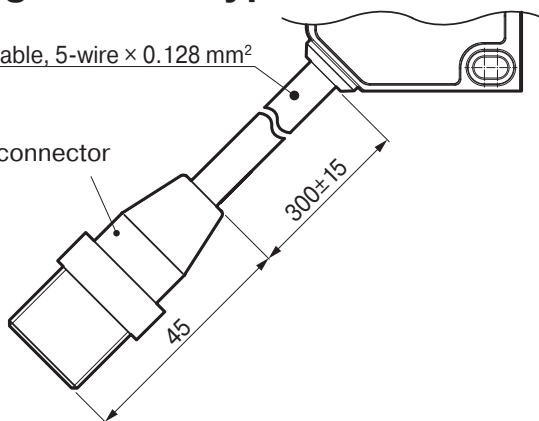

■ M12 5-pin straight open-end cables:

- YF2A15-020VB5XLEAX
- YF2A15-050VB5XLEAX
- YF2A15-100VB5XLEAX

Cable material: PVC, Lead wire nominal cross-section area: 5 cores × 0.34 mm²

L = 2000 (YF2A15-020VB5XLEAX)

= 5000 (YF2A15-050VB5XLEAX)

= 10000 (YF2A15-100VB5XLEAX)

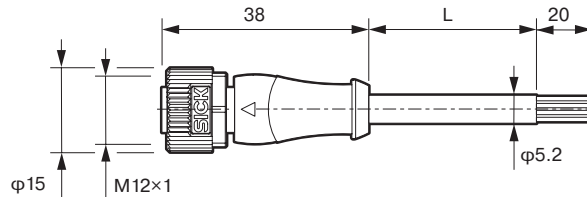

■ M12 5-pin straight open-end bend-resistant cables

- DOL-1205-G02M-R
- DOL-1205-G05M-R

Cable material: PVC, Lead wire nominal cross-section area: 5 cores × 0.3 mm²

L = 2000 (DOL-1205-G02M-R)

= 5000 (DOL-1205-G05M-R)

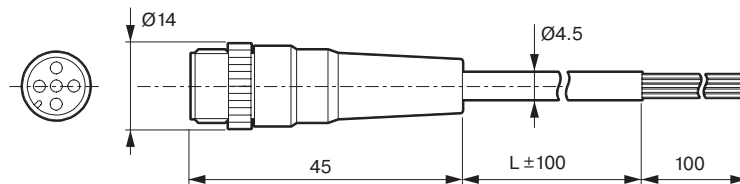

6-3 Characteristics



6-3-1 Spot Size

■ CD2S-30x

(Unit: mm)

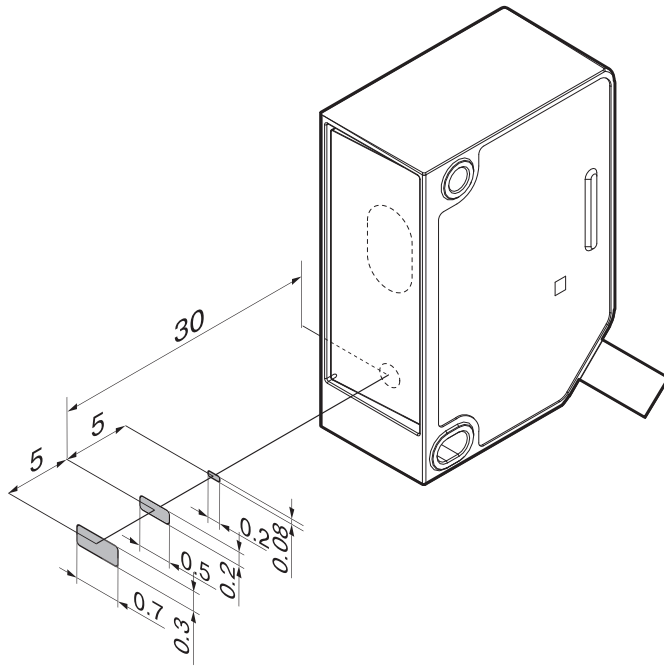

■ CD2S-50x

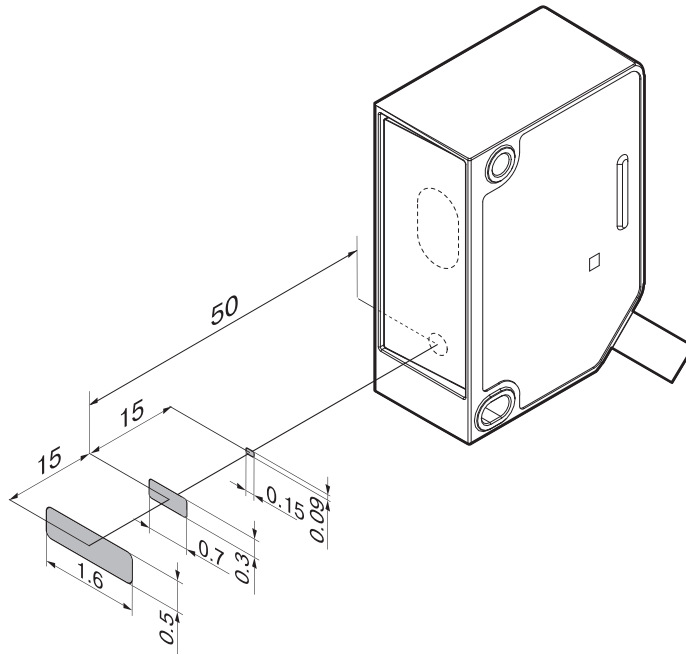

■ CD2S-110x

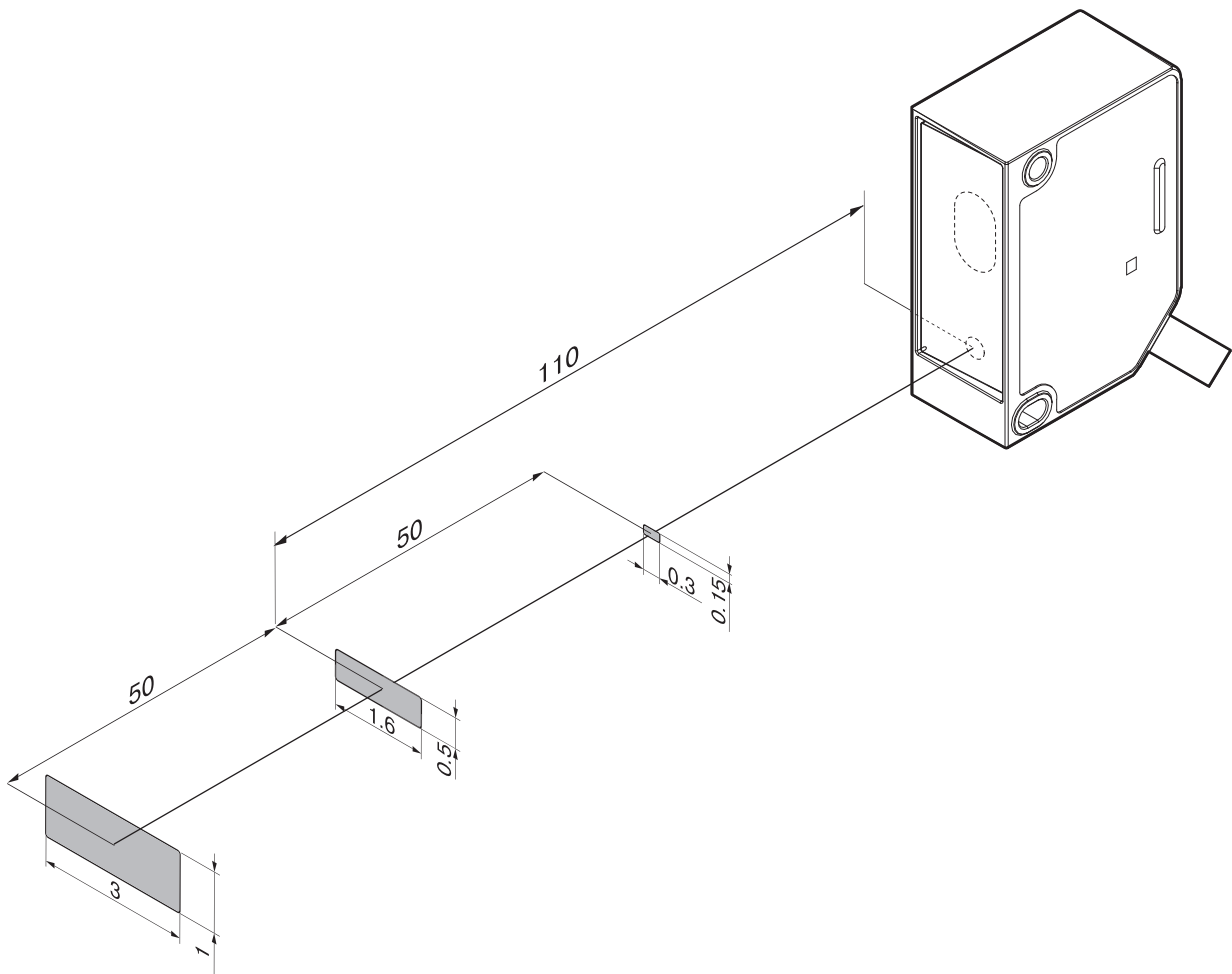

6-3-2 Interference Area

■ CD2S-30x

(Unit: mm)

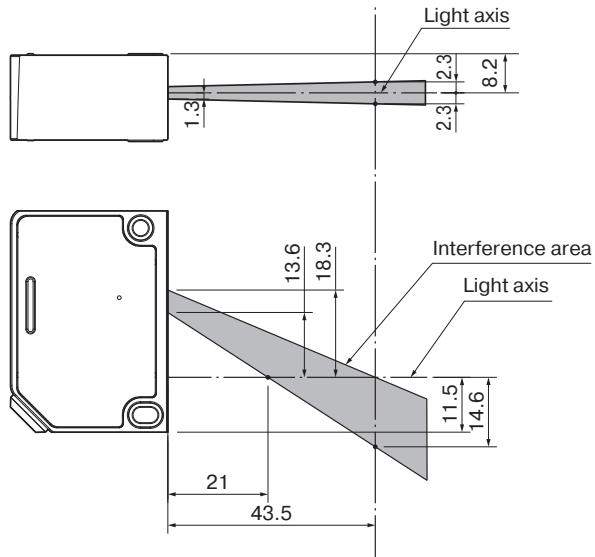

■ CD2S-50x

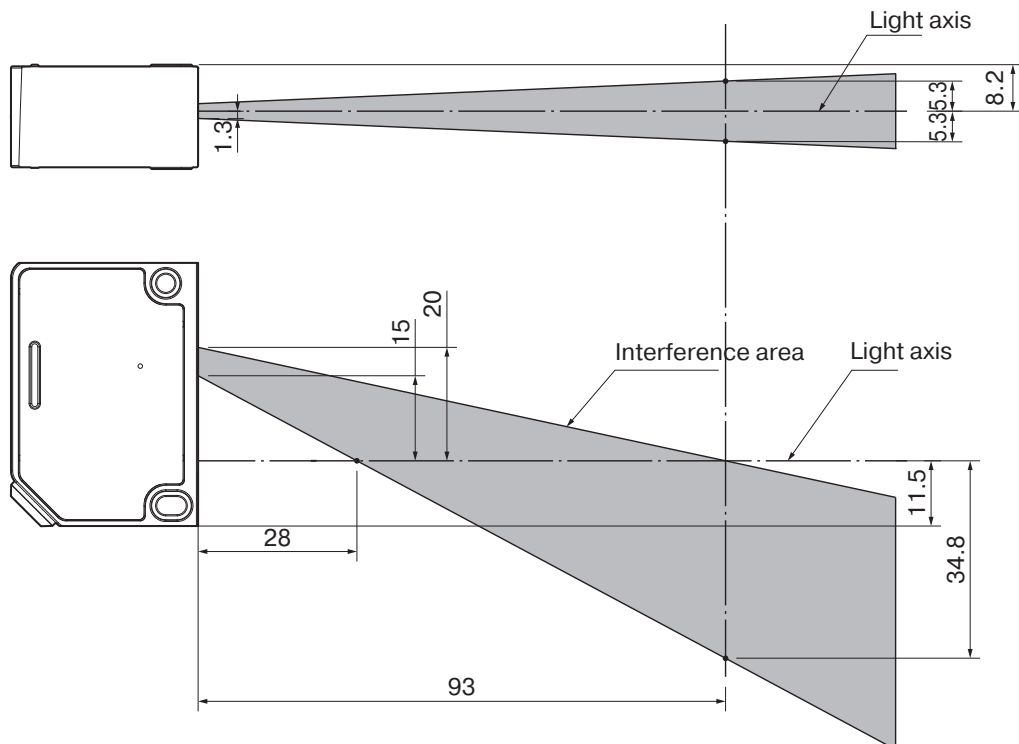

CD2S-110x

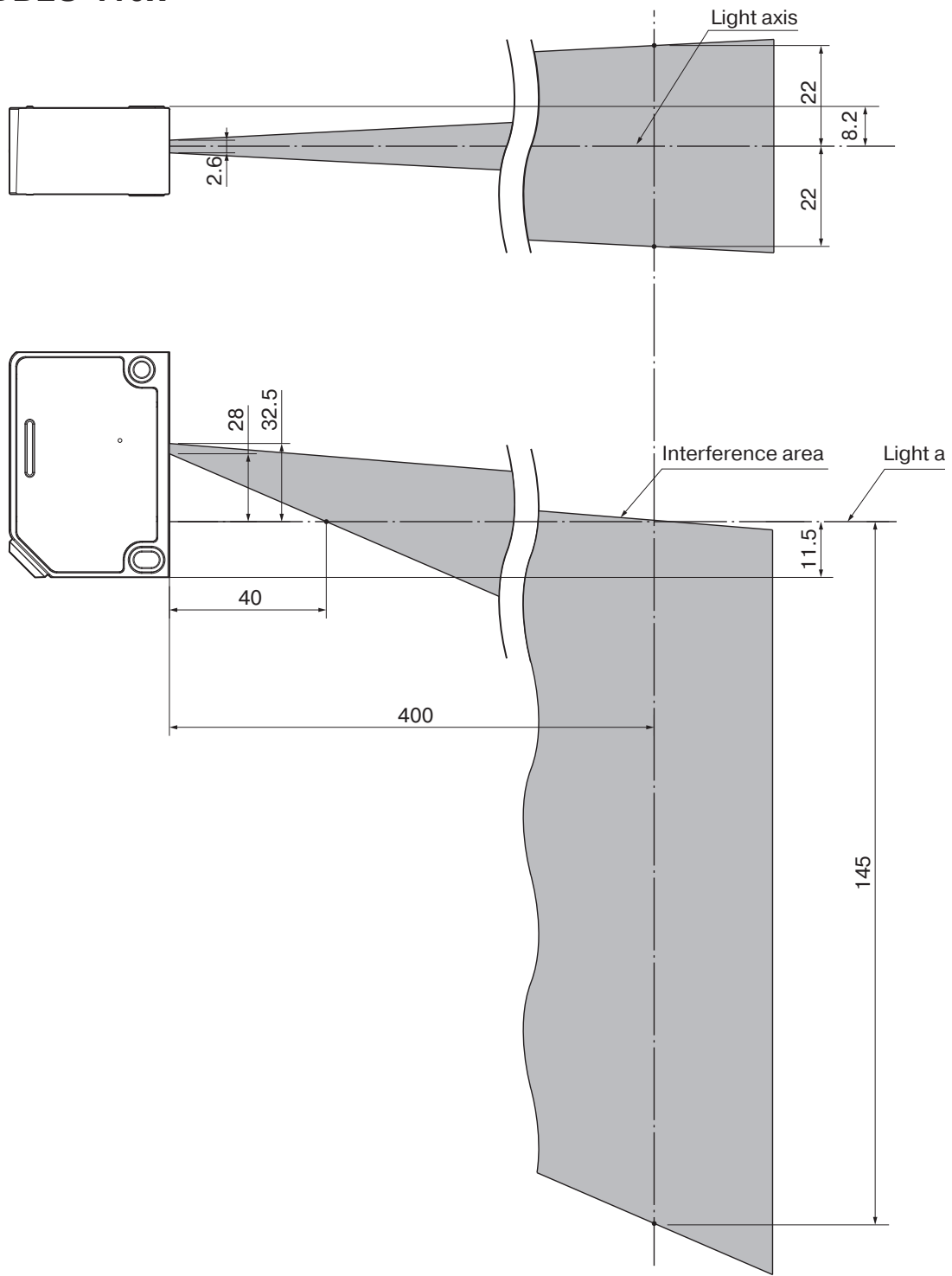

6-3-3 Light Axis Area

■ CD2S-30x

(Unit: mm)

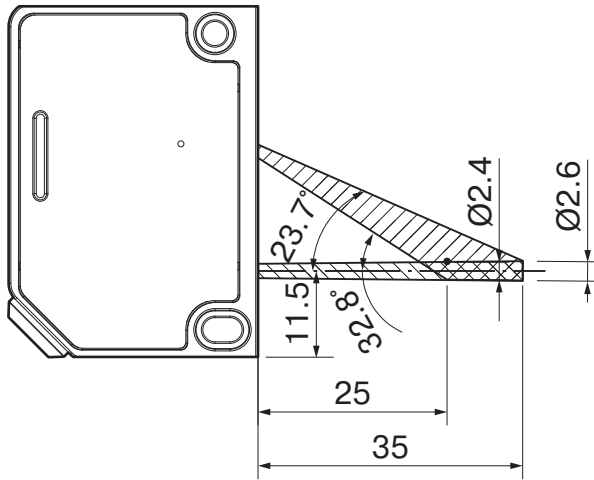

■ CD2S-50x

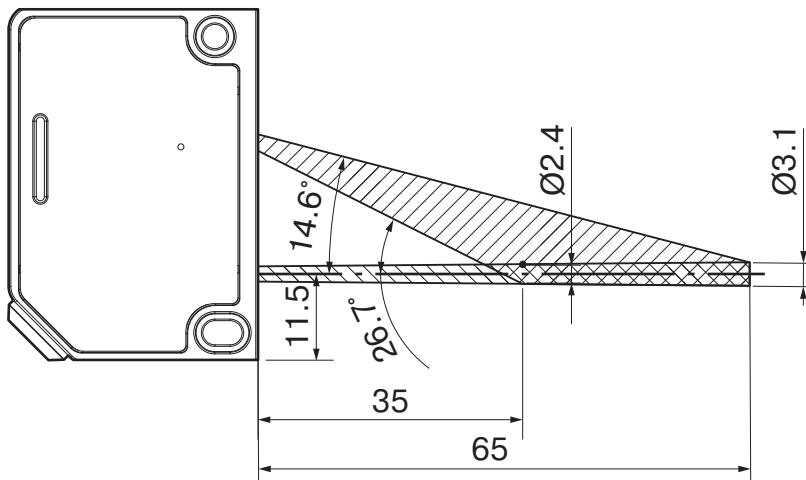

■ CD2S-110x

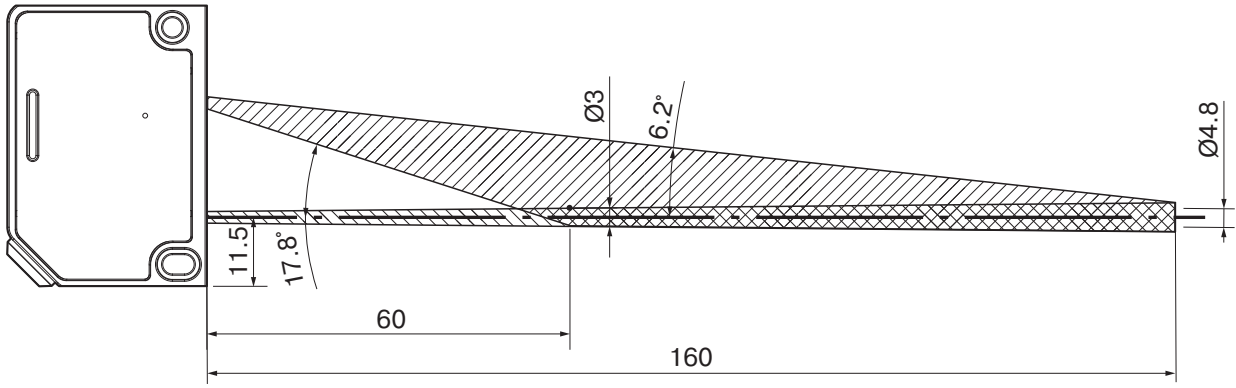



7

Troubleshooting

This chapter describes how to troubleshoot errors that may occur when using this product.

7-1 When an error occurs

There are two types of errors: those that can be displayed using this product's "[G7] Error Counter" or "[G8] Error History", and those that cannot.

7-1-1 Warning indicators shown when an error occurs

When this product experiences an error, the output indicator blinks in red and the details of the error are displayed in "[G7] Error Counter".

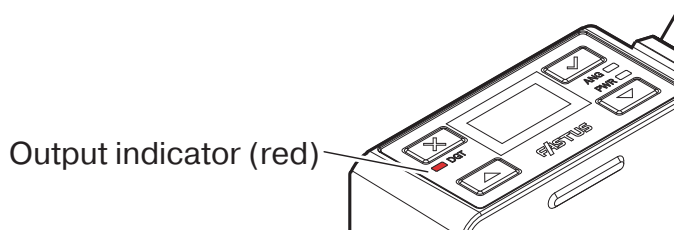

For details on [G7] Error Counter, see See "4-7-7 [G7] Error Counter" (page 4-30).

7-1-2 Error Causes and Troubleshooting



The following shows the cause and troubleshooting method for each type of error number.







Error number	Error details	Cause	Troubleshooting method
1	Sensor high temp.	Product temperature is 70°C or higher	Is the product being used in an environment with a high ambient temperature? Please confirm the operating temperature range before use. If the above is not a problem, there may be a problem with the product itself. Please contact an OPTEX FA sales representative.
2	Sensor low temp.	Product temperature is -20°C or lower	Is the product being used in an environment with a low ambient temperature? Please confirm the operating temperature range before use. If the above is not a problem, there may be a problem with the product itself. Please contact an OPTEX FA sales representative.

Error number	Error details	Cause	Troubleshooting method
3	C/Q overcurrent detection	Large current is flowing to the control output	Is a current of 100 mA or more flowing through the control output? Please adjust the resistance value of the connected load and the supply voltage to within the rated ranges.
4	IO-Link PHY high temperature detection	High ambient temperature	Is the product being used in an environment with a high ambient temperature? Please confirm the operating temperature range before use. If the above is not a problem, there may be a problem with the product itself. Please contact an OPTEx FA sales representative.
5	Supply voltage upper limit error	A power supply voltage of 26.4 V or higher is supplied to this product	Either reduce the supply voltage to within the rated range, or use a power supply that is within the rated voltage range.
6	Supply voltage lower limit error	A power supply voltage of 10.8 V or less is supplied to this product	Either increase the power supply voltage to within the rated range, or use a power supply that is within the rated voltage range.
7	Laser deterioration detection	Deteriorated laser diode	The product is likely nearing the end of its service life. Please consider replacing the product.
8	Analog current output open circuit detection	When "4...20 mA" is selected in [C1] Analog and the white analog output wire or terminal (2) is not connected	If "4...20 mA" is selected in "[C1] Analog Output", make sure that the analog output wire is connected correctly. If the analog output wire is not connected, set "[C1] Analog Output" to anything other than "4...20 mA."
9	Analog voltage output short circuit detection	When "0...10 V" is selected in [C1] Analog and the white analog output wire or terminal (2) is short circuited	Is the analog output line or terminal (2) connected correctly? Check the connection status. If the above is not a problem, there may be a problem with the product itself. Please contact an OPTEx FA sales representative.
10	Analog output overheat detection	Analog output overload	Applying an excessive load on the analog output circuit will cause a current greater than the rated value to flow and generate heat. If the above is not a problem, there may be a problem with the product itself. Please contact an OPTEx FA sales representative.

7-2 What should I do in this situation?

This chapter describes how to troubleshoot problems that may occur when using this product.

Symptom	What to check	Troubleshooting method
Measurement is not possible (Nothing is displayed)	Is power supply voltage being applied?	Confirm that lead wires and connectors are connected securely.
	Is power supply voltage low?	Confirm that the power supply voltage is within the rated range of 18 to 24 V DC $\pm 10\%$.
Measured values are not displayed	Is the measured object within the measurement range?	Make sure to place the measured object properly within the measurement range.
	Are there any obstructions within the measurement range?	Remove any obstructions.
	Is any strong ambient light being emitted from sources such as photoelectric sensors or inverter fluorescent lamps?	Shield the laser receiving part from external light.
	Is the Input Hold Mode function being used?	Confirm the settings for the Input Hold Mode function.  "4-5-1 [D1] Input Function" (page 4-22) If "Input Hold Mode" is selected in "[D1] Input Function", enter the appropriate timing for the setting.  "4-5-2 [D2] Input Hold Mode" (page 4-24)
	Is there mutual interference?	Shield the laser receiving part from laser light from other emitters or photoelectric sensors.
Measured values are unstable	Is the moving average set to a low value (for a fast response time)?	Set a higher moving average.  "4-2-2 [A2] Moving Average" (page 4-4)
	Is the measured object or sensor head vibrating?	Implement vibration countermeasures.
	Is the laser emitting or receiving part dirty or contaminated?	Remove any dirt or contamination.
	Is there any foreign matter such as dirt, contamination, water droplets, or oil droplets on the measured object?	Remove any dirt, contamination, water droplets, or oil droplets.
	Is there any airborne dirt, water droplets, or oil droplets in the operating environment?	Remove dirt and airborne droplets by purging with air, etc.
Measured values are off	Are there any large temperature changes in the operating environment?	Maintain a constant ambient temperature.
	Has the installation position shifted?	Install the product correctly.

Symptom	What to check	Troubleshooting method
Keys do not work	Is the Key Lock function being used?	Cancel the Key Lock function.  "3-1-3 Settings Screen" (page 3-5)
There is no control output	Was wiring performed correctly?	Perform wiring correctly.  "2-2 I/O Circuit Diagrams" (page 2-5)
Control output is incorrect	Is the Output Mode (N.O./N.C.) set correctly?	Set the Output Mode.  "4-3-6 [B6] Output Mode" (page 4-15)
	Is the output type set correctly?	Set the output type.  "4-6-10 [E10] Output Polarity" (page 4-28)
	Are thresholds set correctly?	Set the threshold.  "4-3-3 [B3] Threshold1" (page 4-14)
Analog output is incorrect	Is the analog output type (current/voltage) set correctly?	Set the analog output type.  "4-4-1 [C1] Analog Output" (page 4-20)
	Was wiring performed correctly?	Perform wiring correctly.  "2-2 I/O Circuit Diagrams" (page 2-5)



Attention: Not to be Used for Personnel Protection.

Never use these products as sensing devices for personnel protection. Doing so could lead to serious injury or death. These sensors do not include the self-checking redundant circuitry necessary to allow their use in personnel safety applications. A sensor failure or malfunction can cause either an energized or de-energized sensor output condition. Please consult our distributors about safety products which meet OSHA, ANSI and IEC standards for personnel protection.

- Specifications are subject to change without prior notice.
- Specifications and technical information not mentioned here are written in Instruction Manual. Or visit our website for details.
- All the warnings and cautions to know prior to use are given in Instruction Manual.



OPTEX FA CO., LTD.

91 Chudoji-awata-cho, Shimogyo-ku, Kyoto 600-8115 JAPAN

<https://www.optex-fa.com>

The information in this user's manual is correct as of December 2025

CD2S_UM-E_001_2512