

Reliable Components for Material Handling

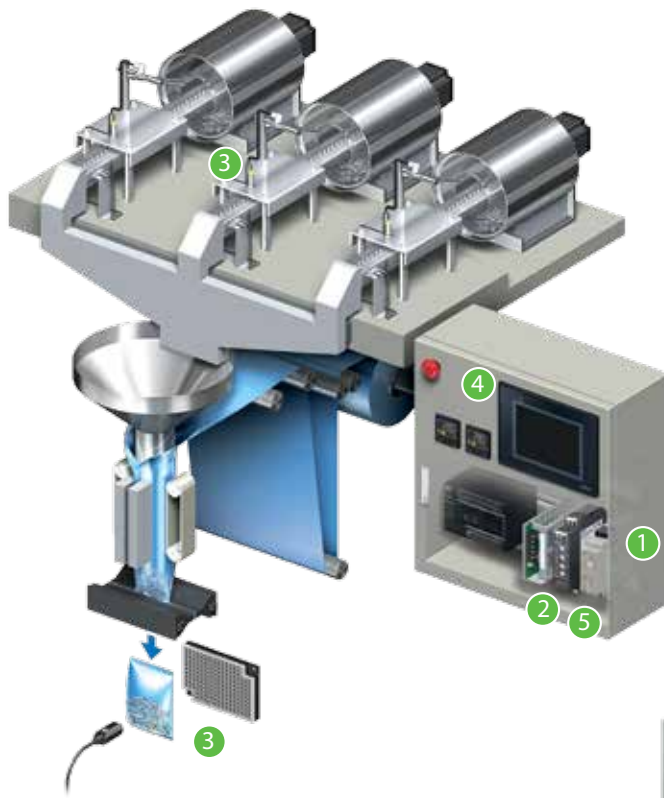

Material handling and parts sorting use these common components:

1. Power Supply (S8VK)
2. Monitoring Relay (K8AK)
3. Photoelectric Sensor (E3FA/E3FB)
4. Pushbutton Switches (A22R)
5. Timer (H3DK)



Palletizers and other material handling equipment use these common components:

6. Power Supply (S8JX)
7. Timer (H3DK)
8. Relays (MY(S))
9. Pushbutton Switches (A22R)
10. Proximity Sensors (E2B)
11. Emergency Stop Switch (A22E)



Control

Power Supplies

S8VK-G series

DIN Rail Mount



- Double set of DC output terminals (three for the negative) to provide easy wiring
- High efficiency (90%) to reduce energy consumption and generate less heat in the control enclosure
- Power Boost functionality (120%) provides power when start-up inrush current is above rated output current

Power Supplies

S8JX-G series

Metal Frame



- Over-voltage, over-current, and short circuit protection
- All models can be DIN-rail, bottom or side mounted for easy installation in any application
- Selection of output voltages includes 5, 12, 15, 24, 48 VDC for a variety of industrial applications

Switching Components

A22R series



- Metal bezel adds to the aesthetic design
- Snap-in switch unit for quick and easy, tool-free assembly
- Complete line of 22 mm pushbuttons, selectors, keyed selectors and pilot lights in both locations

General Purpose Relay

MYS series

Miniature



- High electrical endurance (2 pole: 500,000 ops min, 4 pole: 200,000 ops min) provides sustainable functionality for applications with high switching
- Clear plastic cover allows operator to visually inspect operation of relay, therefore taking the guess work out of the application

Safety

Emergency Stop Devices

A22E



- Direct opening mechanism with minimum contact separation of 3 mm
- E-Stop switches with various head types that include a 30 mm, 40 mm and 60 mm diameter head

Monitoring

Monitoring Relays

K8AK series

Voltage & Current



Quick Link
R634
omron247.com

- The relay warning status is easily monitored with the LED indicator
- Manual resetting and automatic resetting are supported by one relay
- Single-Phase and 3-Phase voltage and current input allows for use in any application world wide

Timers

H3DK series

Multi-Function



Quick Link
T335
omron247.com

- Slim design (22.5 mm width) can be mounted on a DIN rail
- Finger safe termination features captive screws which makes installation quick and easy
- Solid state operation allows H3DK series to be used in applications of high on/off cycling

Sensing

Photoelectric Sensors

E3FA/E3FB series

M18 Size



Quick Link
B278
omron247.com

- High power LED allows sensors to be used in applications which contain dirt and grime build-up
- Visible LED allows for easy alignment for less set-up time
- Short body allows units to be used in applications where traditional photoelectric sensors cannot be used

Proximity Sensors

E2B series

Cylindrical



Quick Link
A289
omron247.com

- All-round-visible indicator allows operation to be seen from all angles
- Pre-wired and connector types available for installation flexibility
- Reliable performance for standard industrial environments

Authorized Distributor: